

Installation Instructions

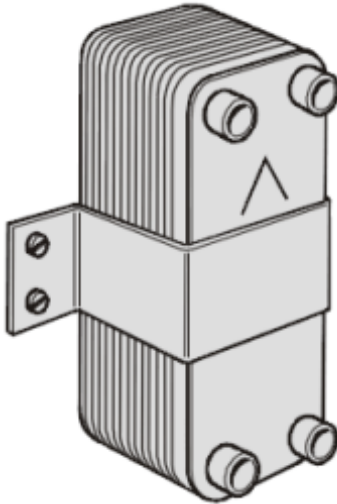

Heat Exchange Systems



This system must be installed and serviced by a qualified person.
Please leave this guide with a responsible officer.

**Notice to Victorian Customers from the
Victorian Building Authority.**

**This heat exchange system must be installed by a licensed person as
required by the Victorian Building Act 1993.**

Only a licensed person will give you a Compliance Certificate, showing that the work complies with all the relevant standards. Only a licensed person will have insurance protecting their workmanship for 6 years. Make sure you use a licensed person to install this water heater and ask for your Compliance Certificate.

CONTENTS

Contents.....	2
Description	3
Pump/C Controller	3
Controller Installation	4
System Installation.....	6
Storage Tanks	6
Heat Exchanger Mounting	6
Plumbing Connections.....	7
Electrical Connections	13
Water Supplies	15
Trouble Shooting	18
Cleaning the Heat Exchanger.....	19
The Rheem Warranty – General.....	22

DESCRIPTION

The Rheem Heat Exchange system is designed to be used to transfer heat from water sourced waste heat applications such as co/tri-generation or mechanical heating circuits.



THIS HEAT EXCHANGE SYSTEM IS NOT SUITABLE FOR APPLICATIONS WHERE REFRIGERANTS ARE USED AS THE HEATING SOURCE, OR WHERE THE PRESSURE IN THE NON-POTABLE SIDE OF THE HEAT EXCHANGER IS LIKELY TO EXCEED THE PRESSURE IN THE POTABLE SIDE.

The heating medium passes through the non-potable side of the heat exchanger. Potable water is pumped from storage tanks to the potable side of the heat exchanger, where it is heated before returning to the tank. The potable water circulating pump operation is controlled by a controlling thermostat which senses the water temperature in the storage tank (Pump/C Controller).

PUMP/C CONTROLLER

Enclosure - The controller enclosure can be installed indoors or outdoors. In order for the controller display to be readily visible it is recommended to not install the controller in direct sunlight.

Operating Thermostat Sensor - The operating thermostat (Eliwell IC902) senses the storage tank water temperature and turns the pump on or off. Adjustments can be made to the thermostat parameters from the front display. The thermostat sensor (grey lead) must be installed in a thermostat well within one of the storage tanks.

Energy Cut Out Thermostat (ECO) – The energy cut out thermostat operates when a condition above the normal temperature requirement has been sensed. It will cut power to the pump and requires a manual operation to reset. The sensing bulb (copper) must be installed in a thermostat well within one of the storage tanks. For convenience, it is suggested to first fit the copper capillary then the thermostat sensor within the same thermostat well.

Pump Control Relay – For a three-phase pump or a single-phase pump with a start current greater than 6 A, pump connections must be made via the coil of a suitably rated relay or contactor. The relay or contactor must be housed in a suitable enclosure and cannot be installed within the Pump/C enclosure. Refer to page 8 for pump selection and page 13 for pump current rating.

CONTROLLER INSTALLATION

Warning! Do not connect the power supply cable to the mains voltage power supply until all connections have been made and the system has been charged with water. Failure to do so can lead to electric shock and/or failure of the pump.

All packaging materials must be removed from the heat exchanger and storage tank prior to their installation.

Mount the controller onto a storage tank within 2m of the pump.

For Rheem 610 series storage tanks, remove the plastic cover to expose the thermostat well, which is located at the front of the storage tank. Drill a small hole in the plastic cover suitable to fit the ECO capillary sensing bulb and feed the ECO capillary sensing bulb through the plastic cover and all the way into the thermostat well. Next feed the thermostat sensor through the plastic cover and fit as far as possible into the thermostat well behind the ECO sensing bulb. Refit the plastic cover.

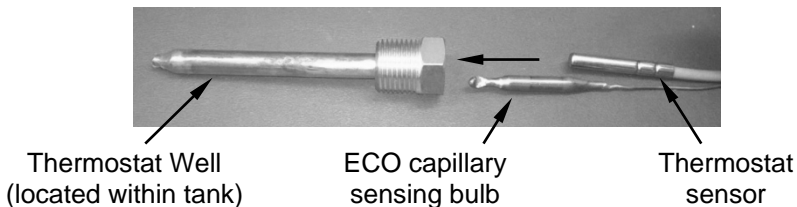

For tanks other than Rheem 610 series, fit a thermostat well into a suitable fitting at the level of the primary hot water flow connection, or lower, in one of the tanks. The well must be 8mm internal diameter minimum and protrude into the tank at least 75mm.

Refer to Electrical Connections on page 13 for wiring of pump.

MODIFYING PUMP/C THERMOSTAT SETTINGS

The parameters of the operating thermostat (Eliwell IC902) may need to be reprogrammed to achieve the desired system operating temperature.

Refer to page 5 for instructions on adjusting the temperature setting.

Note: AS 3498 requires that a water heater provides the means to inhibit the growth of Legionella bacteria in potable water. This water heating system can satisfy this AS 3498 requirement provided it is operating, there is sufficient flow of sufficiently hot water available on the primary

side and the thermostat setting is 60°C or higher, including when it is used as an in-series booster water heater for a solar water heater.

Note: if no buttons are pressed for 15 seconds, settings are not saved and display will revert to show the previous page.



Set Point:

Press and release **set** key. '**SEt**' will be displayed.

Press **set** key again to display the pre-programmed value.

Use **▲** and **▼** arrows to modify set point to the desired temperature.

Press **set** key again to confirm selection.

Press **fnc** key to return to normal operating mode. The current sensed temperature will be displayed.

Differential:

Press and hold **set** key for 5 seconds. '**CP**' will be displayed.

Press the **set** key, '**diF**' will be displayed.

Press **set** key again to display the current differential setting (default 2°C)

Use **▲** and **▼** arrows to adjust the value to the desired differential.

Press **set** key again to confirm selection. '**diF**' will be displayed.

Press '**fnc**' key **twice** to return to normal operating mode. The current sensed temperature will be displayed.

Heat/Cool Mode:

The thermostat should be factory set to heating mode, to check;

Press and hold **set** key for 5 seconds. '**CP**' will be displayed.

Press the **set** key, '**diF**' will be displayed.

Press and release **▲** arrow **3** times. '**HC**' will be displayed.

Press and release **set** button. '**H**' should be displayed to denote that the thermostat is in heat mode.

If '**C**' is displayed, press and release the **▲** arrow to modify setting to '**H**'.

Press **set** key to confirm selection. '**HC**' will be displayed.

Press '**fnc**' key **twice** to return to normal operating mode. The current sensed temperature will be displayed

SYSTEM INSTALLATION

INSTALLATION STANDARDS

The system must be installed:

- by suitably qualified persons, and
- in accordance with these instructions and the instructions supplied with the storage tanks, Pump/C controller and pump, and
- in compliance with Standards AS/NZS 3500.4, AS/NZS 3000, as applicable under local regulations, and all local codes and regulatory authority requirements.

In New Zealand the installation must also conform to the New Zealand Building Code.

STORAGE TANKS

Follow the instructions supplied with the storage tanks for general installation requirements including any location, water quality and maintenance requirements.

HEAT EXCHANGER MOUNTING

The heat exchanger can be mounted horizontally or vertically. Physical constraint of the heat exchanger is not mandatory if mounting the heat exchanger on a flat surface, as shown in fig 1 below, otherwise the heat exchanger must be braced. Two methods are shown in fig 2 and 3 below. A rubber insert must be placed between the heat exchanger and the bracing.

The heat exchanger **MUST NOT** be supported by the pipe work alone.

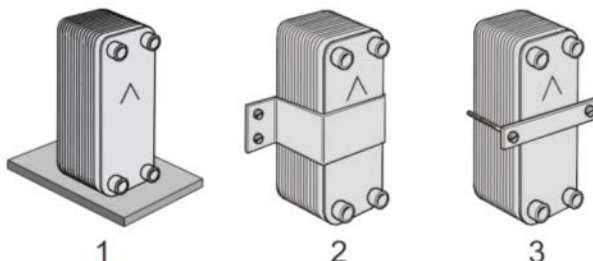

PLUMBING CONNECTIONS

All plumbing work must be carried out by a qualified person and in accordance with the National Plumbing Standard AS/NZS 3500.4 and local authority requirements.

WATER INLET AND OUTLET

Pipe work must be cleared of foreign matter before connection and purged before attempting to operate the system. All olive compression fittings must use brass or copper olives.

An isolation valve, non return valve and line strainer must be installed on the cold water line to the system. A pressure limiting valve must also be fitted if the water supply pressure exceeds 80% of the storage tank TPR valve or expansion control valve setting, whichever is the lower.

SYSTEM CONFIGURATION

Connect the heat exchanger(s), pump and storage tank(s) in accordance with the diagrams on pages 10 and 11 with the following in mind:

- Install storage tanks according to Equa-flow® principles as described in the installation instructions supplied with the storage tanks.
- If multiple heat exchangers are used, install according to Equa-flow® principles as shown in the typical installation diagram on page 11.
- A disconnection union and isolation valve must always be provided at each inlet and outlet on each heat exchanger, pump and storage tank to allow for service and replacement.

PIPE SIZING AND PUMP SELECTION

The table on page 8 specifies the minimum POTABLE cold water and hot water manifold header pipe size required between the Heat Exchanger and the storage tank(s) for typical installations.

NOTE: Pipe sizing, pump selection and installation of the NON-POTABLE circuit is not covered in this manual.

Heat Exchanger Model	Qty in parallel	Output (kW)	Design Flow Rate (L/sec)	Minimum Potable Primary F & R Pipe Size (mm)	Pump Model / Speed Setting
B12Mtx30	1	50	0.61	32	UPS20-60N / 3
B12Mtx30	2	100	1.22	40	UPS32-80N / 3
B12Mtx30	3	150	1.83	50	UPS32-80N / 3
B12Mtx54	1	100	1.2	40	UPS32-80N / 3
B12Mtx54	2	200	2.4	50	UPS40-60/2FB / 2
B12Mtx54	3	300	3.6	65	UPS40-60/2FB / 3
B12Mtx80	1	150	1.82	50	UPS32-80N / 3
B12Mtx80	2	300	3.64	65	UPS40-60/2FB / 3
B12Mtx80	3	450	5.46	80	UPS50-120FB / 2
B12Mtx104	1	200	2.4	50	UPS40-60/2FB / 3
B12Mtx104	2	400	4.8	80	UPS50-120FB / 1
B12Mtx104	3	600	7.2	100	UPS50-120FB / 3
B12Mtx128	1	250	3.03	65	UPS40-60/2FB / 3
B12Mtx128	2	500	6.06	80	UPS50-120FB / 3
B12Mtx128	3	750	9.09	100	UPS80-120FB / 1

Potable Water Pipe and Pump Sizing Chart

Pipe and pump sizing is for potable water side only between the heat exchanger and storage tank/s and is based on 25m TOTAL pipe run and 20 x 90° bends. If the piping is beyond this scope, please contact Rheem for assistance.

HEAT EXCHANGER CONNECTIONS

Connection sizes are G11/4. The connection is designed to use a suitable adapter fitting and sealing gasket. We recommend the use of Water Mark certified thread sealant on all heat exchanger fittings.

Each of the fittings is labelled according to the side of the heat exchanger and the flow.

The front plate of the heat exchanger is marked with an arrow on the cover plate. With the arrow pointing in the direction as shown, the potable water circuit is on the right hand side and the non-potable circuit is on the left hand side as shown in the diagram below.

It is important that counter flow is maintained between the potable and non-potable circuits to achieve maximum heat exchanger efficiency and that the circuits are not cross-connected.

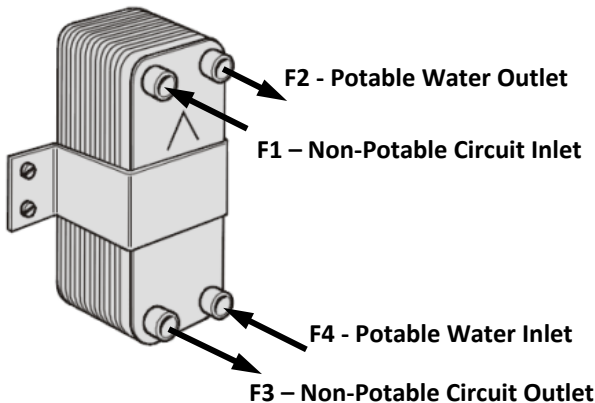

OPERATING PRESSURE

The maximum working pressure of each side of the system will be governed by the lowest operating appliance connected to it. The heat exchanger has a maximum working pressure of 3000kPa.

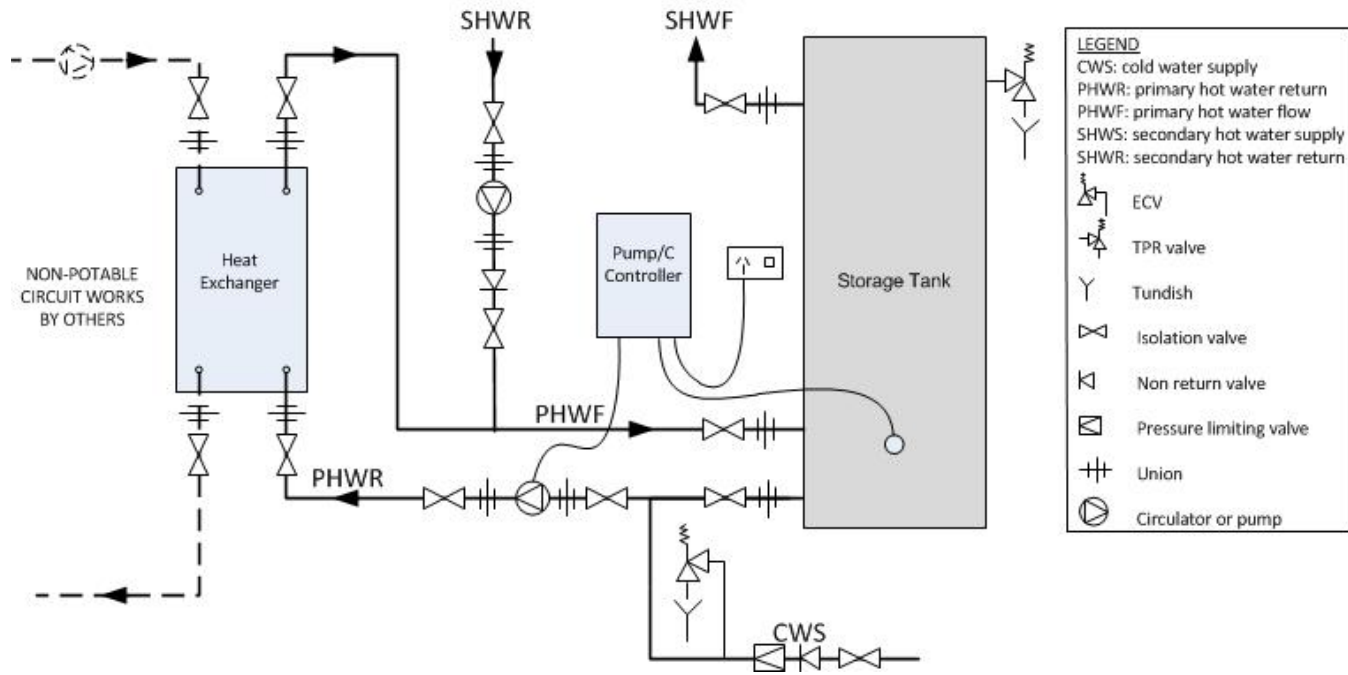

Typical Installation 1 x Heat Exchanger and Storage Tank

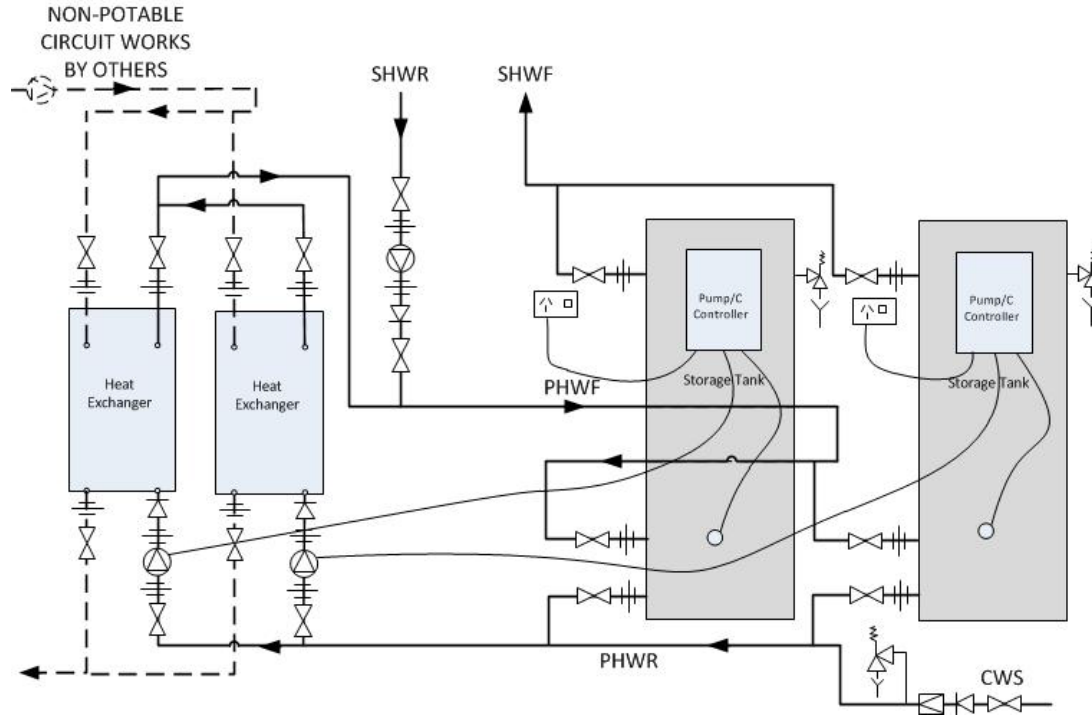

Typical Installation Multiple Heat Exchangers and Multiple Storage Tanks

TEMPERATURE AND PRESSURE RELIEF VALVE

A temperature and pressure relief valve (TPR) is supplied with each storage tank. Refer to the instructions supplied with the storage tanks regarding the fitting of the TPR and drain lines.

EXPANSION CONTROL VALVE

Local regulations may make it mandatory to install an expansion control valve (ECV) in the cold water line to the water heating system. In other areas, an ECV is not required unless the saturation index is greater than +0.4 (refer to 'Water Supplies' in the Instructions supplied with the storage tank). However, an ECV may be needed in a corrosive water area where there are sufficient quantities of silica dissolved in the water.

The expansion control valve must always be installed after the non return valve and be the last valve installed prior to the water heater (refer to diagram on page 10 and 11).

RELIEF VALVE DRAIN

Refer to the instructions supplied with the storage tanks regarding the installation of relief valve drain lines.



Warning: As the function of the temperature pressure relief valve on this water heater system is to discharge high temperature water under certain conditions, it is strongly recommended the pipe work downstream of the relief valve be capable of carrying water exceeding 93°C. Failure to observe this precaution may result in damage to pipe work and property.

ELECTRICAL CONNECTIONS

All electrical work and permanent wiring must be carried out by a qualified person and in accordance with the Wiring Rules AS/NZS 3000 and all local codes and regulatory authority requirements.

 **Warning!** Do not connect the power supply cable to the mains voltage power supply until all connections have been made and the system has been charged with water. Failure to do so can lead to electric shock and/or failure of the pump.

The system will only operate on a sine wave at 50 Hz. Devices generating a square wave cannot be used to supply power to the system.

A 240V/50Hz general purpose outlet is required to supply power to the Pump/C controller.

Connect the pump to the pump terminals marked A₁, N and E in the Pump/C controller in accordance with the instructions supplied with the pump. For a three-phase pump or a single-phase pump with a start current greater than 6 A, pump connections must be made via the coil of a suitably rated relay or contactor. The relay or contactor must be housed in a suitable enclosure and cannot be installed within the Pump/C enclosure.

Maximum start current for the recommended Grundfos pumps with 240V/50Hz supply voltage are as follows:

Pump Model	Current per Phase (Amps)	Single or Three Phase
UPS20-60N	0.5	Single
UPS32-80N	1.0	Single
UPS40-60/2FB	1.3	Single
UPS50-120FB	3.6	Single
UPS80-120FB	2.75	Three

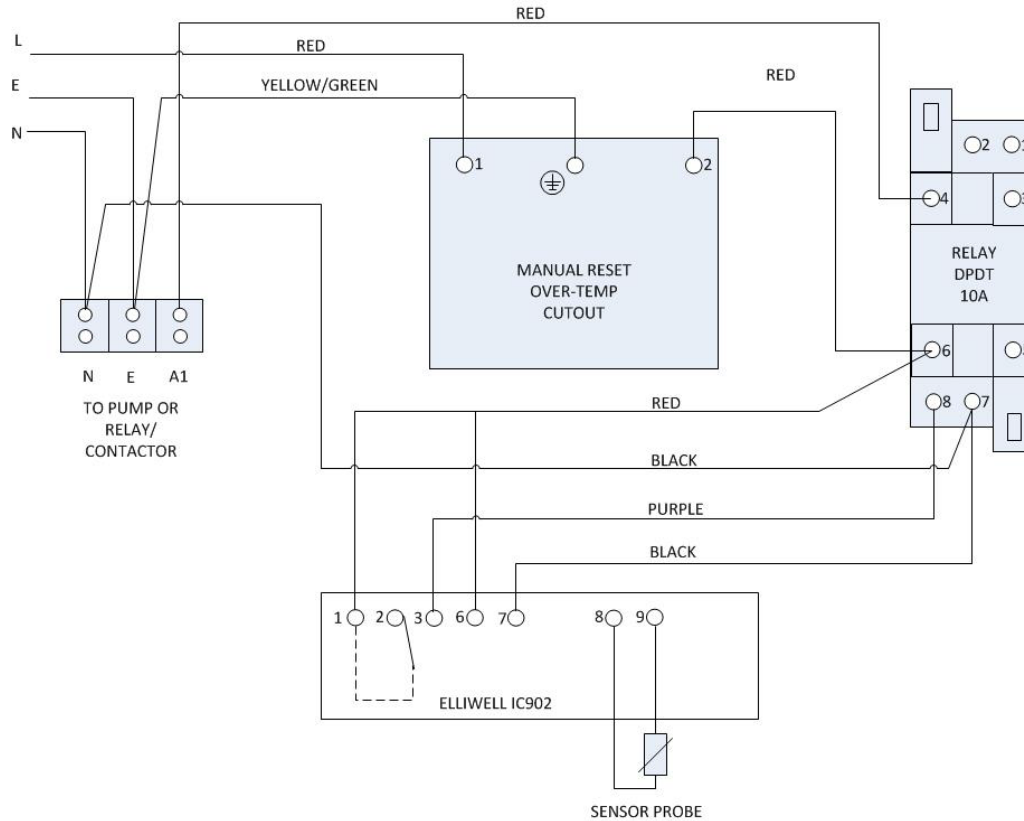

Wiring Diagram – Pump/C Controller

WATER SUPPLIES

This heat exchanger system must be installed in accordance with this advice to be covered by the Rheem warranty.

This heat exchanger system is manufactured to suit the water conditions of most public reticulated water supplies. However, there are some known water chemistries which can have detrimental effects on the heat exchanger system and its operation and / or life expectancy. If you are unsure of your water chemistry, you may be able to obtain information from your local water supply authority. This heat exchanger system should only be connected to a water supply which complies with these guidelines for the Rheem warranty to apply.

CHANGE OF WATER SUPPLY

The changing or alternating from one water supply to another can have a detrimental effect on the operation and / or life expectation of a number of components in this heat exchanger system.

Where there is a changeover from one water supply to another, e.g. a rainwater tank supply, bore water supply, desalinated water supply, public reticulated water supply or water brought in from another supply, then water chemistry information should be sought from the supplier or it should be tested to ensure the water supply meets the requirements given in these guidelines for the Rheem warranty to apply.

SATURATION INDEX

The saturation index (SI) is used as a measure of the water's corrosive or scaling properties.

Where the saturation index is less than -1.0 , the water is very corrosive and the Rheem warranty does not apply to the heat exchanger system. In a corrosive water supply, the water can attack copper parts and cause them to fail.

Where the saturation index exceeds $+0.40$, the water is very scaling and an expansion control valve* must be fitted on the cold water line after the non-return valve for the Rheem warranty to apply to a Rheem storage tank. The Rheem warranty does not apply to the heat exchanger.

Water which is scaling may be treated with a water softening device to reduce the saturation index of the water.

* Refer to the cold water connection detail supplied with the storage tank and on page 10 and 11 of this manual.

CHLORIDE AND PH

In a high chloride water supply, the water can corrode stainless steel parts and cause them to fail. Where the chloride level exceeds the limits shown in the table below the Rheem warranty does not apply to the heat exchanger system.

CHLORIDE CONTENT	MAXIMUM TEMPERATURE			
	60°C	80°C	120°C	130°C
= 10 ppm	SS 304	SS 304	SS 304	SS 316
= 25 ppm	SS 304	SS 304	SS 316	SS 316
= 50 ppm	SS 304	SS 316	SS 316	Ti / 254 SMO
= 80 ppm	SS 316	SS 316	SS 316	Ti / 254 SMO
= 150 ppm	SS 316	SS 316	Ti / 254 SMO	Ti / 254 SMO
= 300 ppm	SS 316	Ti / 254 SMO	Ti / 254 SMO	Ti / 254 SMO
> 300 ppm	Ti / 254 SMO	Ti / 254 SMO	Ti / 254 SMO	Ti / 254 SMO

pH is a measure of whether the water is alkaline or acid. In an acidic water supply, the water can attack stainless steel parts and cause them to fail. Where the pH is less than the recommended level shown in the table of water content below, the Rheem warranty does not apply to the heat exchanger system.

Water with a low pH may be treated to raise the pH. The water supply from a rainwater tank in a metropolitan area is likely to be corrosive due to the dissolution of atmospheric contaminants.

SUMMARY OF WATER CHEMISTRY ADVICE AFFECTING THE RHEEM WARRANTY

The heat exchanger is not suitable for certain water chemistries. The following table is to be considered a guide to the corrosion resistance of stainless steels and brazing materials in tap water at room temperature. In the table a number of important chemical components are listed, however the actual corrosion is a very complex process influenced by many different components in combination.

Rheem's warranty will not cover any resultant faults if the water heater is connected at any time to a water supply that exceeds the limits listed in the table.

EXPLANATIONS:

+ Good resistance under normal conditions
 0 Corrosion problems may occur especially when more factors are valued 0
 - Use is not recommended

WATER CONTENT	CONCENTRATION (mg/l or ppm)	TIME LIMITS Analyze before	AISI 316	COPPER
Alkalinity (HCO ⁻)	< 70	Within 24 h	+	0
	70-300		+	+
	> 300		+	0/+
Sulphate ^[1] (SO ₄ ²⁻)	< 70	No limit	+	+
	70-300		+	0/+
	> 300		+	-
HCO ₃ ⁻ / SO ₄ ²⁻	> 1.0	No limit	+	+
	< 1.0		+	0/-
Electrical conductivity	< 10 μS/cm	No limit	+	0
	10-500 μS/cm		+	+
	> 500 μS/cm		+	0
pH ^[2]	< 6.0	Within 24 h	0	0
	6.0-7.5		+	0
	7.5-9.0		+	+
	>9.0		+	0
Ammonium (NH ₄ ⁺)	< 2	Within 24 h	+	+
	2-20		+	0
	>20		+	-
Chlorides (Cl ⁻) <i>Please also see table below</i>	<100		+	+
	100 - 200		+	+
	200 – 300		+	+
	>300		-	0/+
Free chlorine (Cl ₂)	<1	Within 5 h	+	+
	1 – 5		-	0
	>5		-	0/-
Hydrogen sulphide (H ₂ S)	<0.05	No limit	+	+
	>0.05		+	0/-
Free (aggressive) carbon dioxide (CO ₂)	<5	No limit	+	+
	5 – 20		+	0
	>20		+	-
Total hardness (°dH)	4.0 – 8.5	No limit	+	+
Nitrate ^[1] (NO ₃ ⁻)	<100	No limit	+	+
	>100		+	0
Iron ^[3] (Fe)	<0.2	No limit	+	+
	>0.2		+	0
Aluminium (Al)	<0.2	No limit	+	+
	>0.2		+	0
Manganese ^[3] (Mn)	<0.1	No limit	+	+
	>0.1		+	0

[1] Sulfates and nitrates works as inhibitors for pitting corrosion caused by chlorides in pH neutral environments

[2] In general low pH (below 6) increase corrosion risk and high pH (above 7.5) decrease the corrosion risk [3] Fe³⁺ and Mn⁴⁺ are strong oxidants and may increase the risk for localised corrosion on stainless steels SiO₂ above 150ppm increase the risk of scaling

PRESSURE RATING

	Primary	Secondary
Max working pressure at 155°C	31 bar	28 bar
Max working pressure at 225°C	27 bar	25 bar
Test pressure	50 bar	45 bar

TEMPERATURE RATING

- Min temperature: -196°C
- Max temperature: 225°C

TROUBLE SHOOTING

Check the items below before making a service call. You will be charged for attending to any condition or fault that is not related to manufacture or failure of a part.

No digital display - Some possible causes are:

1. Power Outage.
2. Over-temperature thermostat tripped out.
3. Loose or open circuit wiring.
4. Thermostat faulty.
5. Direct sunlight on LCD.

Probe Failure - Error message “E1” will be displayed if there is a problem with the temperature probe. Reasons for “E1” error message are:

1. Temperature probe lead has been severed.
2. Temperature probe connections at thermostat terminals have broken/disconnected.
3. Temperature probe is damaged/faulty.

Water too hot - Ensure the operating thermostat temperature probe is fully inserted into cylinder temperature sensing well and is unhindered in its ability to accurately sense the cylinder temperature.

Check the pump switches off when the when the temperature reaches the OFF set point.

Water not hot enough – Is there sufficient hot water available on the potable side? Check the pump switches on when the temperature drops below the ON set point.

CLEANING THE HEAT EXCHANGER

Should the heat exchanger require cleaning, e.g. due to operation in hard water at high temperatures, it is possible to clean the heat exchanger. Use a tank with weak acid, 5% phosphoric acid or, if the heat exchanger is frequently cleaned, 5% oxalic acid. Remove from the system and circulate cleaning fluid through the heat exchanger, ideally at 1.5 times the normal flow rate and in reverse flow.

Flush the heat exchanger water ways with clean water and then before the final rinse with water, rinse with a solution of 1-2% sodium hydroxide (NaOH) or sodium bicarbonate (NaHCO_3) to neutralise all acid.

This page is intentionally blank

This page is intentionally blank

HEAT EXCHANGE AND PUMP/C WARRANTY – AUSTRALIA ONLY

1. HEAT EXCHANGER, PUMP-C CONTROLLER MODEL 6060262-4 & PUMP THE RHEEM WARRANTY – GENERAL

- 1.1 This warranty is given by Rheem Australia Pty Limited ABN 21 098 823 511 of 1 Alan Street, Rydalmere New South Wales.
- 1.2 Rheem offer a trained and qualified national service network who will repair or replace components at the address of the water heater subject to the terms of the Rheem warranty. Rheem Service, in addition can provide preventative maintenance and advice on the operation of your water heater. The Rheem Service contact number is available 7 days a week on 131 031 with Service personnel available to take your call from 8am to 8pm daily (hours subject to change).
- 1.3 For details about this warranty, you can contact us on 131 031 or by email at warrantyenquiry@rheem.com.au (not for service bookings).
- 1.4 The terms of this warranty and what is covered by it are set out in section 2 and 3 and apply to water heaters manufactured after 1st July 2014.
- 1.5 If a subsequent version of this warranty is published, the terms of that warranty and what is covered by it will apply to water heaters manufactured after the date specified in the subsequent version.

2. TERMS OF THE RHEEM WARRANTY AND EXCLUSIONS TO IT

- 2.1 The decision of whether to repair or replace a faulty component is at Rheem's sole discretion.
- 2.2 Where a failed component or cylinder is replaced under this warranty, the balance of the original warranty period will remain effective. The replacement does not carry a new Rheem warranty.
- 2.3 Where the water heater is installed outside the boundaries of a metropolitan area as defined by Rheem or further than 25 km from either a regional Rheem branch office or an Accredited Rheem Service Agent's office, the cost of transport, insurance and travelling between the nearest branch office or Rheem Accredited Service Agent's office and the installed site shall be the owner's responsibility.
- 2.4 Where the water heater is installed in a position that does not allow safe or ready access, the cost of that access, including the cost of additional materials handling and/or safety equipment, shall be the owner's responsibility. In other words, the cost of dismantling or removing cupboards, doors or walls and the cost of any special equipment to bring the water heater to floor or ground level or to a serviceable position is not covered by this warranty.
- 2.5 This warranty only applies to the original and genuine Rheem water heater in its original installed location and any genuine Rheem replacement parts.
- 2.6 If the water heater is not sized to supply the hot water demand in accordance with the guidelines in Rheem's water heater literature, any resultant fault will not be covered by the Rheem warranty.

- 2.7 The Rheem warranty does not cover faults that are a result of:
- a) Accidental damage to the water heater or any component (for example: (i) Acts of God such as floods, storms, fires, lightning strikes and the like; and (ii) third party acts or omissions).
 - b) Misuse or abnormal use of the water heater.
 - c) Installation not in accordance with the Owner's Guide and Installation Instructions or with relevant statutory and local requirements in the State or Territory in which the water heater is installed.
 - d) Connection at any time to a water supply that does not comply with the water supply guidelines as outlined in the Owner's Guide and Installation Instructions.
 - e) Repairs, attempts to repair or modifications to the water heater by a person other than Rheem Service or a Rheem Accredited Service Agent.
 - f) Faulty plumbing or faulty gas or power supply.
 - g) Failure to maintain the water heater in accordance with the Owner's Guide and Installation Instructions.
 - h) Transport damage.
 - i) Fair wear and tear from adverse conditions (for example, corrosion).
 - j) Cosmetic defects.
 - k) Ice formation in the waterways of a water heater: where the electricity supply has been switched off or has failed and the water heater has not been drained in accordance with the instructions; or due to an ambient temperature below -20°C (including wind chill factor).
- 2.8 If you require a call out and we find that the fault is not covered by the Rheem warranty, you are responsible for our standard call out charge. If you wish to have the relevant component repaired or replaced by Rheem, that service will be at your cost.
- 2.9 Subject to any statutory provisions to the contrary, this warranty excludes any and all claims for damage to furniture, carpet, walls, foundations or any other consequential loss either directly or indirectly due to leakage from the water heater, or due to leakage from fittings and/ or pipe work of metal, plastic or other materials caused by water temperature, workmanship or other modes of failure.

3. WHAT IS COVERED BY THE RHEEM WARRANTY FOR THE HEAT EXCHANGER, CONTROLLER AND PUMP DETAILED IN THIS DOCUMENT

- 3.1 Rheem will repair or replace a faulty component of your heat exchanger, controller and pump if it fails to operate in accordance with its specifications as follows:

What components are covered	The period in which the fault must appear in order to be covered	What coverage you receive
All components	Year 1	Repair and/or replacement of the faulty component, free of charge, including labour.

4. ENTITLEMENT TO MAKE A CLAIM UNDER THIS WARRANTY

- 4.1 To be entitled to make a claim under this warranty you need to:
- 4.2 Be the owner of the water heater or have consent of the owner to act on their behalf.
- 4.3 Contact Rheem Service without undue delay after detection of the defect and, in any event, within the applicable warranty period.
- 4.4 You are **not** entitled to make a claim under this warranty if your water heater:
- 4.5 Does not have its original serial numbers or rating labels.
- 4.6 Is not installed in Australia.

5. HOW TO MAKE A CLAIM UNDER THIS WARRANTY

- 5.1 If you wish to make a claim under this warranty, you need to:
- 5.2 Contact Rheem on 131031 and provide owner's details, address of the water heater, a contact number and date of installation of the water heater or if that's unavailable, the date of manufacture and serial number (from the rating label on the water heater).
- 5.3 Rheem will arrange for the water heater to be tested and assessed on-site.
- 5.4 If Rheem determines that you have a valid warranty claim, Rheem will repair or replace the faulty component in accordance with this warranty.
- 5.5 Any expenses incurred in the making of a claim under this warranty will be borne by you.

6. THE AUSTRALIAN CONSUMER LAW

- 6.1 Our goods come with guarantees that cannot be excluded under the *Australian Consumer Law*. You are entitled to a replacement or refund for a major failure and for compensation for any other reasonably foreseeable loss or damage. You are also entitled to have the goods repaired or replaced if the goods fail to be of acceptable quality and the failure does not amount to a major failure.
- 6.2 The Rheem warranty (set out above) is in addition to any rights and remedies that you may have under the *Australian Consumer Law*.

RHEEM AUSTRALIA PTY LTD
A.B.N. 21 098 823 511
www.rheem.com.au

FOR SERVICE TELEPHONE
131 031 AUSTRALIA
0800 657 335 NEW ZEALAND