

Installation Instructions



Pump/C Controller

This water heater must be installed and serviced by a qualified person.
Please leave this guide with a responsible officer.

**Notice to Victorian Customers from the
Victorian Building Authority.**

**This water heater system must be installed by a licensed person as
required by the Victorian Building Act 1993.**

Only a licensed person will give you a Compliance Certificate, showing that the work complies with all the relevant standards. Only a licensed person will have insurance protecting their workmanship for 6 years. Make sure you use a licensed person to install this water heater and ask for your Compliance Certificate.

CONTENTS

Contents.....	2
Pump/C Controller	3
Description	3
Installation.....	4
Modifying Pump/C Thermostat Settings	5
System Installation.....	8
Svpak / Tankpak Installation.....	10
Plumbing Connections	11
Electrical Connections	15
Trouble Shooting	17
The Rheem Warranty – General.....	18

PUMP/C CONTROLLER

DESCRIPTION

The Pump C controller is used to control continuous flow water heaters (CFWH) when used in conjunction with a direct or indirect storage tank. The controller senses temperature within the storage tank and controls a pump which in turn causes the CFWH to fire or cease firing.

Enclosure

The controller enclosure can be installed indoors or outdoors. In order for the controller display to be readily visible it is recommended to not install the controller in direct sunlight.

Operating Thermostat Sensor - The operating thermostat (Eliwell IC902) senses the storage tank water temperature and turns the pump on or off. Adjustments can be made to the thermostat parameters from the front display. The sensor is connected to the thermostat via a grey lead which must be installed in the thermostat well within one of the storage tanks.

Energy Cut Out Thermostat – The energy cut out thermostat operates when a condition above the normal temperature requirement has been sensed. It will cut power to the pump and requires a manual operation to reset. The sensor is connected to the thermostat via a copper capillary tube.

The energy cut out thermostat is only required for use where CFWH are being used in conjunction with Edwards GXC or LEX storage tanks for use in controlled warm water temperature applications such as nursing homes, hospitals, and schools, etc, below 50°C. If the system is being used to provide hot water at temperatures above 50°C in SV or Tankpak installations, the energy cut out thermostat need not be installed. The capillary tube should be coiled up and stored preferably behind the controller.

Pump Control Relay – If the pump start current exceeds 6 Amps, connect the pump to the coil of a suitably rated relay or contactor. The relay or contactor must be housed in a suitable enclosure and cannot be installed within the Pump/C enclosure. This will be required for Grundfos pump models CM 5-2 or larger.

CONTROLLER INSTALLATION

Warning! Do not connect the power supply cable to the mains voltage power supply until all connections have been made and the system has been charged with water. Failure to do so can lead to electric shock and/or failure of the pump.

Mount the controller onto a storage tank or wall adjacent to the storage tank and within 2m of the pump and storage tank.

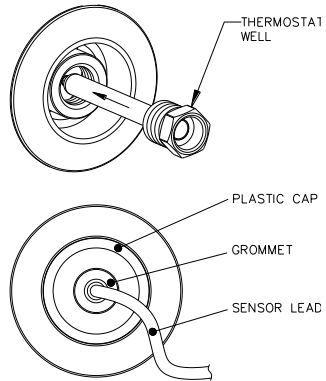

For SV or 610 series storage tanks, remove the plastic cover to expose the thermostat well, which is located at the front of the storage tank. Drill a small hole in the plastic cover suitable to fit the thermostat sensing probe and feed the wire through the plastic cover and all the way into the thermostat well. Refit the plastic cover.

For GXC and LEX tanks feed the thermostat probe and energy cut out sensor one after the other into the thermostat well which is located on the front of the storage tank.

For tanks other than SV or 610 series, fit a thermostat well into a suitable fitting at the level of the primary hot water flow connection, or lower, in one of the tanks. The well must be 8mm internal diameter minimum and protrude into the tank at least 75mm.

Refer to Electrical Connections on page 15 and 16 for wiring of pump.

MODIFYING THERMOSTAT SETTINGS

The parameters of the operating thermostat (Eliwell IC902) and continuous flow water heaters (if used as the heat source) may need to be reprogrammed to achieve the desired system operating temperature.

Refer to the table and instructions on page 5 and 6 for instructions on adjusting the temperature setting.

Note: AS 3498 requires that a water heater provides the means to inhibit the growth of Legionella bacteria in potable water. This water heater can satisfy this AS 3498 requirement provided it is operating and the thermostat setting is 60°C or higher, including when it is used as an in-series booster water heater for a solar water heater.

System Operating Temperature (°C)	27L CFWH Thermostat Setting (°C)	Eliwell Thermostat Set Point (°C)	Eliwell Thermostat Differential (°C)
60	65	60	3
65	70	65	3
70	75	70	3
75	82	75	3
82	82	80	3

MODIFYING PUMP/C THERMOSTAT SETTINGS

Note: if no buttons are pressed for 15 seconds, settings are not saved and display will revert to show the previous page.

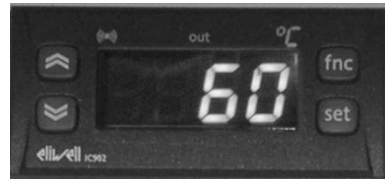

Set Point:

Press and release **set** key. '**SEt**' will be displayed.

Press **set** key again to display the pre-programmed value.

Use ▲ and ▼ arrows to modify set point to the desired temperature.

Press **set** key again to confirm selection.

Press **fnc** key to return to normal operating mode. The current sensed temperature will be displayed.

Differential:

Press and hold **set** key for 5 seconds. '**CP**' will be displayed.

Press the **set** key, '**diF**' will be displayed.

Press **set** key again to display the current differential setting (default 2°C)

Use ▲ and ▼ arrows to adjust the value to the desired differential.

Press **set** key again to confirm selection. '**diF**' will be displayed.

Press '**fnc**' key **twice** to return to normal operating mode. The current sensed temperature will be displayed.

Heat/Cool Mode:

The thermostat should be factory set to heating mode, to check;

Press and hold **set** key for 5 seconds. **'CP'** will be displayed.

Press the **set** key, **'dIF'** will be displayed.

Press and release **▲** arrow **3** times. **'HC'** will be displayed.

Press and release **set** button. **'H'** should be displayed to denote that the thermostat is in heat mode.

If **'C'** is displayed, press and release the **▲** arrow to modify setting to **'H'**.

Press **set** key to confirm selection. **'HC'** will be displayed.

Press **'fnc'** key **twice** to return to normal operating mode. The current sensed temperature will be displayed.

TO CHECK OR ADJUST THE PRESET OUTLET TEMPERATURE SETTING OF THE CONTINUOUS FLOW WATER HEATERS

The temperature settings will be displayed on the LED display. The preset outlet temperature settings are:

872 / 862 / 372 / 362 series:

38°C, 40°C, 42°C, 43°C, 45°C, 50°C, 55°C, 60°C, 65°C, 70°C, 75°C, 82°C

It is necessary to have the electrical supply to the water heater switched on during stages of checking or adjusting the preset outlet temperature setting procedure.

⚠ Warning: The removal of the front panel will expose 240 volt wiring. Take care not to touch wiring terminals. The adjustment must be carried out by a qualified person.

⚠ Warning: This procedure will involve the adjustment of dip switches. Adjustment of a dip switch should only be made with an insulated tool.

To check or adjust the preset outlet temperature setting:

1. Switch off the electrical supply at the power outlet to the water heater.
2. Remove the front panel jacket screws.
3. Gently disengage the front panel and pull forward to remove from the water heater.
4. Switch on the electrical supply at the power outlet to the water heater.
5. Switch dip switches 3 and 4 to the on (up) position on the DIP 1 set of DIP switches on the I.C. Board.

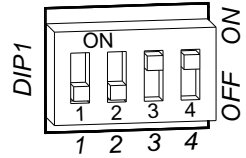

The current preset outlet temperature setting will show on the LED display.

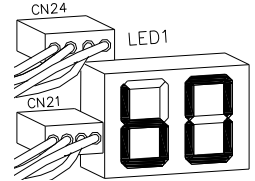

If the temperature shown on the LED display is the desired preset outlet temperature setting, then proceed to step 7. No further adjustment is necessary.

6. Press the MAX button to increase or the MIN button to decrease the preset outlet temperature setting. Each press of the MAX or MIN button will increase or decrease the preset temperature by one increment. The MAX and MIN buttons are located underneath the DIP 1 and DIP 2 set of DIP switches.

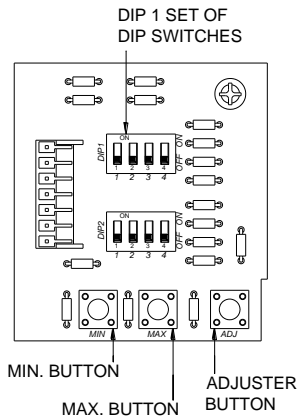

872 / 862 / 372 / 362 series

The increments are 38, 40, 42, 43, 45, 50, 55, 60, 65, 70, 75, 82.

Set the LED display to 82 if it is required to deliver sanitising temperatures.

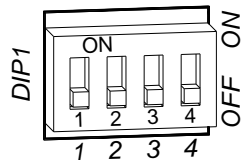

7. Switch dip switches 3 and 4 to the off (down) position.

The LED display will go blank. The preset outlet temperature setting is now set.

8. Switch off the electrical supply at the power outlet to the water heater.
9. Refit the front panel and screws to the water heater.

SYSTEM INSTALLATION

Refer to the Owners Manual and Installation Instructions supplied with the product for installation of Edwards GXC, LEX, HEV or SHX water heaters.

For SVpak or Tankpak systems incorporating SV or 610 series direct storage tanks follow the instructions commencing on page 10.

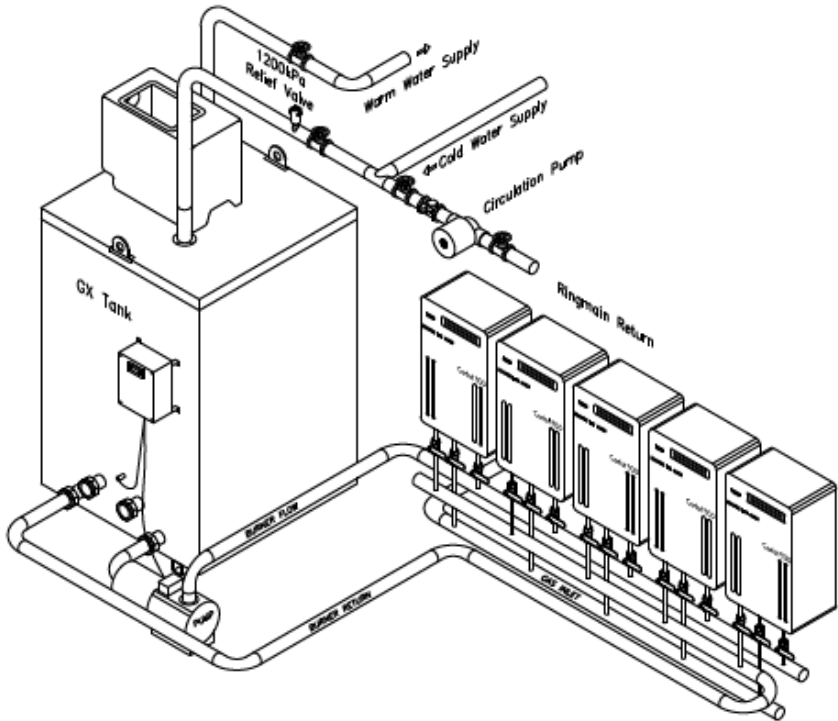

Typical Installation GXC with CFWH Heat Source

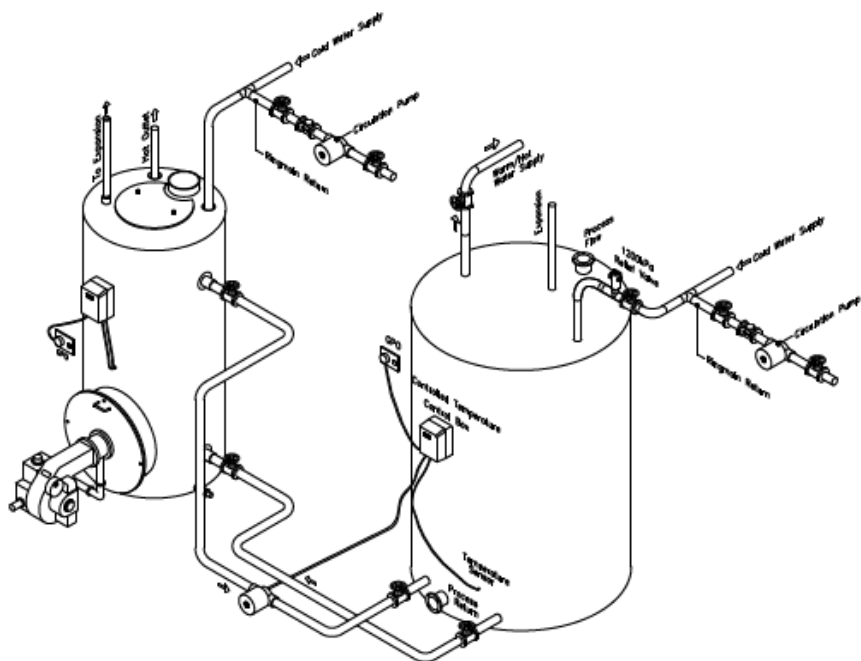

Typical Installation LEX with HEV Heat Source

SVPAK / TANKPAK INSTALLATION

INSTALLATION STANDARDS

The water heater system must be installed:

- By suitably qualified persons, and
- in accordance with these instructions and the instructions supplied with the storage tanks, Pump/C controller and pump, and
- in compliance with Standards AS/NZS 3500.4, AS/NZS 3000 and AS 5601 or AS/NZS 5601.1, as applicable under local regulations, and all local codes and regulatory authority requirements.

In New Zealand the installation must also conform to the New Zealand Building Code.

GENERAL

Follow the instructions supplied with the water storage tank and CFWH for general installation requirements including any fluing, location, water quality and maintenance requirements.

OPERATION

SVpak and Tankpak operate on the top down heating principle. This ensures the coldest water is always supplied to the CFWH to maximise thermal input and recovery. On a call for heat, the thermostat energises the pump, the flow from which in turn causes the CFWH to fire simultaneously. The rate of fire will depend on the thermostat set point, the flow rate from the pump and the incoming water supply temperature. Water at the set temperature of the CFWH will enter the top of the storage tank or the hot water delivery to the building (or both depending on system dynamics) and heat the storage tank from the top down, until a temperature above the controlling thermostat set point is sensed at the thermostat, at which time the pump will be de-energised and the CFWH will shut down. Pump run-on is not required for use with CFWH.

All packaging materials must be removed from the water heater and storage tank prior to its installation.

PLUMBING CONNECTIONS

All plumbing work must be carried out by a qualified person and in accordance with the National Plumbing Standard AS/NZS 3500.4 and local authority requirements.

All gas work must be carried out by a qualified person and in accordance with the Australian Gas Installations Standard AS 5601 or AS/NZS 5601.1, AS3814 and local authority requirements.

WATER INLET AND OUTLET

All pipe work must be cleared of foreign matter before connection and purged before attempting to operate the water heater. All olive compression fittings must use brass or copper olives. Use thread sealing tape or approved thread sealant on all other fittings.

An isolation valve, non return valve and line strainer must be installed on the cold water line to the system. A pressure limiting valve must also be fitted if the water supply pressure exceeds 80% of the storage tank temperature and pressure relief valve or expansion control valve setting, whichever is the lower.

WATER HEATER CONNECTIONS

Connect the water heater, pump and storage tank(s) in accordance with the principles shown in the diagram on page 13 with the following in mind:

- Install the storage tanks according to Equa-flow® principles as described in the installation instructions supplied with the storage tanks.
- Install the water heaters according to Equa-flow® principles as shown in the diagram on page 13.
- A disconnection union must always be provided at the cold water inlet, hot water outlet and gas connection on the water heaters to allow for disconnection of the water heaters.

PIPE SIZING AND PUMP SELECTION

The table below specifies the minimum cold water and hot water manifold header pipe size required between the CFWH and the storage tank(s) and the minimum gas manifold pipe size for typical installations.

Where CFWH are supplied pre assembled, and the system requires more than six (6) CFWH, each manifold assembly must be plumbed in parallel. Installing the manifolds in series will lead to higher than acceptable velocity in the pipe line and/or induce too much restriction on the pump resulting in less than optimum flow and recovery.

No CFWH	Thermal Input (MJ/hr)	Minimum Primary Flow and Return Pipe Size (mm)	Minimum Gas Pipe Size (mm)		Single Phase Pump Model
			NG	Prop	
1	205	25	25	20	UPS32-80N
2	410	25	40	25	CM3-2
3	615	25	40	25	CM3-2
4	820	32	50	32	CM3-2
5	1025	40	50	32	CM5-2
6	1230	40	50	32	CM5-2
7	1435	50	50	32	CM5-2
8	1640	50	65	40	CM10-1
9	1845	50	65	40	CM10-1
10	2050	50	65	40	CM10-1
12	2460	50	80	40	CM10-1
14	2870	65	80	50	CM10-1
16	3280	65	80	50	CM10-1
18	3690	80	100	50	CM10-1

Pipe and Pump Sizing Chart

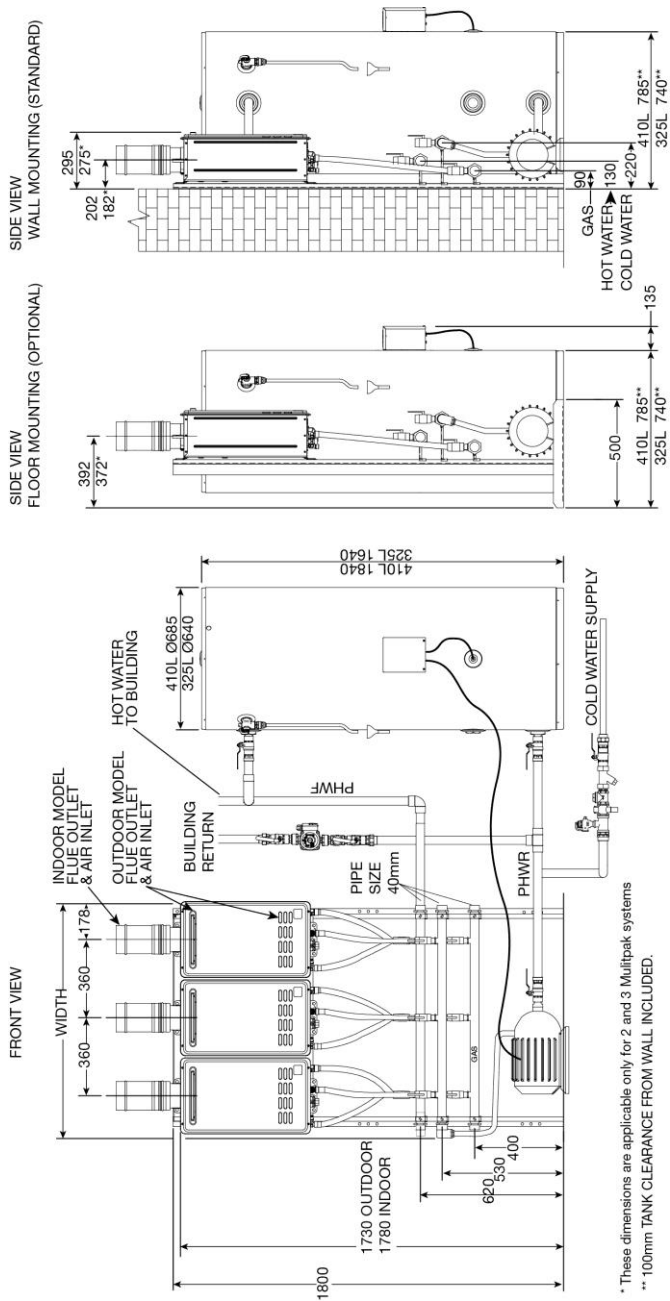

* These dimensions are applicable only for 2 and 3 Multipak systems
 ** 100mm TANK CLEARANCE FROM WALL INCLUDED.

Typical Installation SV or 610 Series Direct Storage with CFWH Heat Source

TEMPERATURE AND PRESSURE RELIEF VALVE

A temperature and pressure relief valve (TPR) is supplied with each storage tank. Refer to the instructions supplied with the storage tanks regarding the fitting of the TPR and drain lines.

EXPANSION CONTROL VALVE

Local regulations may make it mandatory to install an expansion control valve (ECV) in the cold water line to the water heating system. In other areas, an ECV is not required unless the saturation index is greater than +0.4 (refer to 'Water Supplies' in the Instructions supplied with the storage tank). However, an ECV may be needed in a corrosive water area where there are sufficient quantities of silica dissolved in the water.

The expansion control valve must always be installed after the non return valve and be the last valve installed prior to the water heater (refer to diagram on page 9). A copper drain line must be run separately from the drain of the relief valve.

RELIEF VALVE DRAIN

Refer to the instructions supplied with the storage tanks regarding the installation of relief valve drain lines.

For multiple installations the drain line from each storage tank can discharge into a common tundish.



Warning: As the function of the temperature pressure relief valve on this water heater system is to discharge high temperature water under certain conditions, it is strongly recommended the pipe work downstream of the relief valve be capable of carrying water exceeding 93°C. Failure to observe this precaution may result in damage to pipe work and property.

GAS INLET

The pipe work must be cleared of foreign matter before connection and purged before attempting to light the water heater. An isolation valve and disconnection union must be used to allow servicing and removal of the water heater. Refer to AS 5601 or AS/NZS 5601.1 for the correct pipe sizing.



Always isolate the water heater before pressure testing the gas supply system. Disconnect the water heater after the isolating cock to prevent the risk of serious damage to the gas train. Warranty does not cover damage of any nature resulting from failure to observe this precaution. Refer to the rating label for gas types and pressures.



The heater and its gas connection must be thoroughly leak tested before placing in operation. Use soapy water and a manometer for leak test.

DANGER! Do not use an open flame to check for gas leaks.

ELECTRICAL CONNECTIONS

All electrical work and permanent wiring must be carried out by a qualified person and in accordance with the Wiring Rules AS/NZS 3000 and all local codes and regulatory authority requirements.



Warning! Do not connect the power supply cable to the mains voltage power supply until all connections have been made and the system has been charged with water. Failure to do so can lead to electric shock and/or failure of the pump.

The water heater will only operate on a sine wave at 50 Hz. Devices generating a square wave cannot be used to supply power to the water heater.

A 240V/50Hz general purpose outlet is required to supply power to the Pump/C controller and to each CFWH.

Each CFWH has a maximum current draw of 0.75 Amps.

Connect the pump to the pump terminals marked A₁, N and E in the Pump/C controller.

If the pump start current exceeds 6 Amps, connect the pump wire to the coil of a suitably rated relay or contactor. The relay or contactor must be housed in a suitable enclosure and cannot be installed within the Pump/C enclosure. This will be required for Grundfos pump models CM 5-2 or larger.

Maximum start current for Grundfos pumps with 240V/50Hz supply voltage are as follows:

UPS32-80N	1.0A
CM 3-2	6.0A
CM 5-2	14.8A
CM 10-1	15.6A

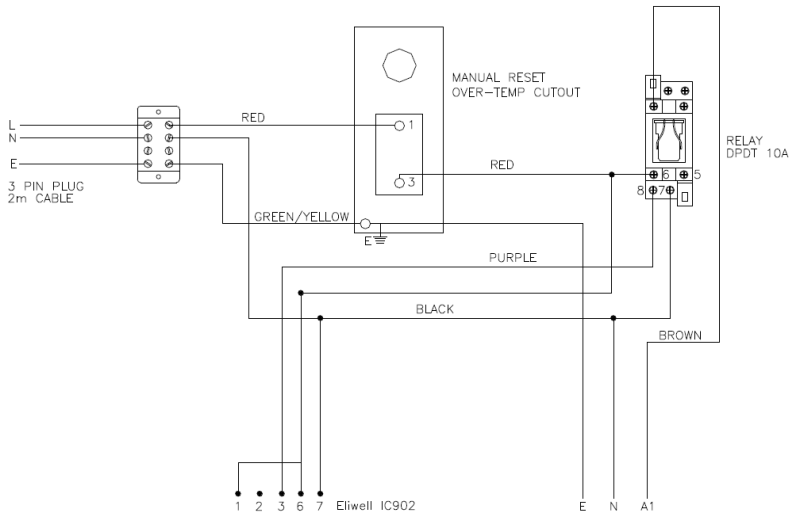

Wiring Diagram – Pump/C Controller

TROUBLE SHOOTING

When a complaint is lodged about the performance of a hot water system there are a number of causes that should be checked and eliminated. In an attempt to pinpoint the most likely cause it is important to discuss with the customer their reasons for the complaint, the duration of the problem, any change in circumstances or usage. This information in conjunction with the following listed common complaints will assist you in locating the most likely cause.

No digital display - Some possible causes are:

1. Power Outage.
2. Over-temperature thermostat tripped out.
3. Loose or open circuit wiring.
4. Thermostat faulty.
5. Direct sunlight on LCD.

Probe Failure - Error message “E1” will be displayed if there is a problem with the temperature probe. Reasons for “E1” error message are:

1. Temperature probe lead has been severed.
2. Temperature probe connections at thermostat terminals have broken/disconnected.
3. Temperature probe is damaged/faulty.

Water too hot - Ensure the operating thermostat temperature probe is fully inserted into cylinder temperature sensing well and is unhindered in its ability to accurately sense the cylinder temperature.

PUMP/C WARRANTY – AUSTRALIA ONLY

1. PUMP/C CONTROLLER MODEL 6060262 – 4 AND PUMP

THE RHEEM WARRANTY – GENERAL

- 1.1 This warranty is given by Rheem Australia Pty Limited ABN 21 098 823 511 of 1 Alan Street, Rydalmere New South Wales.
- 1.2 Rheem offer a trained and qualified national service network who will repair or replace components at the address of the water heater subject to the terms of the Rheem warranty. Rheem Service, in addition can provide preventative maintenance and advice on the operation of your water heater. The Rheem Service contact number is available 7 days a week on 131 031 with Service personnel available to take your call from 8am to 8pm daily (hours subject to change).
- 1.3 For details about this warranty, you can contact us on 131 031 or by email at warrantyenquiry@rheem.com.au (not for service bookings).
- 1.4 The terms of this warranty and what is covered by it are set out in section 2 and 3 and apply to water heaters manufactured after 1st June 2013.
- 1.5 If a subsequent version of this warranty is published, the terms of that warranty and what is covered by it will apply to water heaters manufactured after the date specified in the subsequent version.

2. TERMS OF THE RHEEM WARRANTY AND EXCLUSIONS TO IT

- 2.1 The decision of whether to repair or replace a faulty component is at Rheem's sole discretion.
- 2.2 Where a failed component or cylinder is replaced under this warranty, the balance of the original warranty period will remain effective. The replacement does not carry a new Rheem warranty.
- 2.3 Where the water heater is installed outside the boundaries of a metropolitan area as defined by Rheem or further than 25 km from either a regional Rheem branch office or an Accredited Rheem Service Agent's office, the cost of transport, insurance and travelling between the nearest branch office or Rheem Accredited Service Agent's office and the installed site shall be the owner's responsibility.
- 2.4 Where the water heater is installed in a position that does not allow safe or ready access, the cost of that access, including the cost of additional materials handling and/or safety equipment, shall be the owner's responsibility. In other words, the cost of dismantling or removing cupboards, doors or walls and the cost of any special equipment to bring the water heater to floor or ground level or to a serviceable position is not covered by this warranty.
- 2.5 This warranty only applies to the original and genuine Rheem water heater in its original installed location and any genuine Rheem replacement parts.
- 2.6 If the water heater is not sized to supply the hot water demand in accordance with the guidelines in Rheem's water heater literature, any resultant fault will not be covered by the Rheem warranty.

- 2.7 The Rheem warranty does not cover faults that are a result of:
- a) Accidental damage to the water heater or any component (for example: (i) Acts of God such as floods, storms, fires, lightning strikes and the like; and (ii) third party acts or omissions).
 - b) Misuse or abnormal use of the water heater.
 - c) Installation not in accordance with the Owner's Guide and Installation Instructions or with relevant statutory and local requirements in the State or Territory in which the water heater is installed.
 - d) Connection at any time to a water supply that does not comply with the water supply guidelines as outlined in the Owner's Guide and Installation Instructions.
 - e) Repairs, attempts to repair or modifications to the water heater by a person other than Rheem Service or a Rheem Accredited Service Agent.
 - f) Faulty plumbing or faulty gas or power supply.
 - g) Failure to maintain the water heater in accordance with the Owner's Guide and Installation Instructions.
 - h) Transport damage.
 - i) Fair wear and tear from adverse conditions (for example, corrosion).
 - j) Cosmetic defects.
 - k) Ice formation in the waterways of a water heater: where the electricity supply has been switched off or has failed and the water heater has not been drained in accordance with the instructions; or due to an ambient temperature below -20°C (including wind chill factor).
- 2.8 If you require a call out and we find that the fault is not covered by the Rheem warranty, you are responsible for our standard call out charge. If you wish to have the relevant component repaired or replaced by Rheem, that service will be at your cost.
- 2.9 Subject to any statutory provisions to the contrary, this warranty excludes any and all claims for damage to furniture, carpet, walls, foundations or any other consequential loss either directly or indirectly due to leakage from the water heater, or due to leakage from fittings and/ or pipe work of metal, plastic or other materials caused by water temperature, workmanship or other modes of failure.

3. WHAT IS COVERED BY THE RHEEM WARRANTY FOR THE CONTROLLER AND PUMP DETAILED IN THIS DOCUMENT

- 3.1 Rheem will repair or replace a faulty component of your controller if it fails to operate in accordance with its specifications as follows:

What components are covered	The period in which the fault must appear in order to be covered	What coverage you receive
All components	Year 1	Repair and/or replacement of the faulty component, free of charge, including labour.

4. ENTITLEMENT TO MAKE A CLAIM UNDER THIS WARRANTY

- 4.1 To be entitled to make a claim under this warranty you need to:
- 4.2 Be the owner of the water heater or have consent of the owner to act on their behalf.
- 4.3 Contact Rheem Service without undue delay after detection of the defect and, in any event, within the applicable warranty period.
- 4.4 You are **not** entitled to make a claim under this warranty if your water heater:
- 4.5 Does not have its original serial numbers or rating labels.
- 4.6 Is not installed in Australia.

5. HOW TO MAKE A CLAIM UNDER THIS WARRANTY

- 5.1 If you wish to make a claim under this warranty, you need to:
- 5.2 Contact Rheem on 131031 and provide owner's details, address of the water heater, a contact number and date of installation of the water heater or if that's unavailable, the date of manufacture and serial number (from the rating label on the water heater).
- 5.3 Rheem will arrange for the water heater to be tested and assessed on-site.
- 5.4 If Rheem determines that you have a valid warranty claim, Rheem will repair or replace the faulty component in accordance with this warranty.
- 5.5 Any expenses incurred in the making of a claim under this warranty will be borne by you.

6. THE AUSTRALIAN CONSUMER LAW

- 6.1 Our goods come with guarantees that cannot be excluded under the *Australian Consumer Law*. You are entitled to a replacement or refund for a major failure and for compensation for any other reasonably foreseeable loss or damage. You are also entitled to have the goods repaired or replaced if the goods fail to be of acceptable quality and the failure does not amount to a major failure.
- 6.2 The Rheem warranty (set out above) is in addition to any rights and remedies that you may have under the *Australian Consumer Law*.

RHEEM AUSTRALIA PTY LTD
A.B.N. 21 098 823 511
www.rheem.com.au

FOR SERVICE TELEPHONE
131 031 AUSTRALIA
0800 657 335 NEW ZEALAND