

Rheem Heat Pump Water Heating

RHEEM HEAT PUMP WATER HEATERS			
MODEL	HDi-310	MPI-325	MPs-325 split
HP INPUT	1300W	800W	800W
LITRES	310	325	325
DIMENSIONS	1865 x 670	1631 x 863	1637 x 676 - 1034 x 575
HP OUTPUT	3.7kW	1.77kW	1.77kW
INSTALLATION	External	External	Internal/External
WARRANTY	7 years	7 years	7 years



An Introduction

Relying on the principles and componentry of reverse cycle air-conditioners, combined with renewable air-sourced heat energy, heat pump water heaters provide similar benefits to a solar water heater without the need to install roof mounted solar panels. Through the use of refrigeration and air conditioning technology, heat is extracted from the surrounding air, concentrated and transferred into the stored water, discharging cold air back to the atmosphere.

By using the available ambient heat in the atmosphere, on average for every 1kW of electrical energy used to operate the heat pump control system, 3 kW of heat is transferred into the water. This makes the heat pump 300% efficient, using approximately 1/3 the electricity of an electric water heater. This saves up to 2/3 off a consumer's hot water energy consumption, which means lower operating costs compared to an electric water heater on continuous tariff. This also benefits the environment as it displaces demand for electricity which would otherwise result in higher greenhouse gas emissions. This reduction in greenhouse gas emissions can be as much as 3.6 tonnes per year when replacing an electric water heater on continuous tariff.



How it Works

Rheem Heat Pump Water Heaters use vapour compression technology as its principle of operation. A fan draws surrounding air through an evaporator, where heat is absorbed by low temperature refrigerant. The refrigerant is then compressed and becomes hot, high pressure gas. The heat is then transferred from the refrigerant to cold water pumped from the bottom of the water tank through a flat plate heat exchanger. As heat is transferred from the refrigerant to the water in the heat exchanger, the refrigerant is cooled. Finally, the refrigerant pressure is lowered via a thermostatic expansion (TX) valve, ready for the cycle to be repeated. After passing through the heat exchanger the water is delivered back to the cylinder. With the MPI – 325 the heated water is delivered back to a mid-way position in the tank, awaiting its next pass through the heat exchanger. The MPI-325 relies on multiple passes to heat the water to 60°C, where in contrast the top down heating feature on HDi-310 heats water to 60°C in a single pass.

The heat pump function of the water heater is most efficient between 7°C and 40°C and will operate well outside this range depending on water usage patterns. An important design feature of the Rheem heat pump is water temperature stratification. The Rheem heat pump design provides a consistent level of water temperature throughout the tank, heating the water to between 60°C and 61°C

When Does a Rheem Heat Pump Water Heater Work

A Rheem heat pump water heater works at any time, regardless of the temperature of the surrounding air or the weather conditions. The simplest method of operation is to leave the Rheem heat pump connected to the electrical power supply and allow the electronic controller to control the operation.

Faster heating and more efficient electricity use is achieved when the surrounding air is warmer. This means the Rheem heat pump is best operated during the day. It is recommended to connect the heat pump to a continuous electricity supply.

Performance of the Rheem heat pump water heater will vary from location to location. Performance is a function of ambient temperature, humidity, incoming cold water temperature, seasonal variations and the amount of supplementary boosting required.

Quality

The heat pump control system also offers a degree of protection in harsh environments, such as along the coastline. The evaporator is coated with an anti-corrosive solvent resistant (blue) coating. The coating is usually described as an epoxy or sometimes a phenolic coating. In addition the evaporator end plates are made of galvanised steel. The coating and galvanised end plates provide protection against salt air, which means for installations along the coast line, the unit is not unduly affected by the more aggressive atmosphere.

The drip tray, which catches the condensate from the heat extraction process and the fan shroud are made of a solvent resistant plastic, whilst the fan blades are an alloy material. The fan motor, compressor and receiver dryer are also provided with a protective coating.

The internal storage cylinder is manufactured from mild steel and protected with Rheem's proven Rheemglas vitreous enamel lining. Further protection is provided by a sacrificial anode. This combination makes the water heater suitable for a wide range of water supplies, however areas with extremely poor water quality do pose the threat of blockage to some heat pump components in the water circuit.

To ensure the water stays hotter for longer, a dense layer of pressure injected CFC free polyurethane foam insulation is used between the steel cylinder and Colorbond jacket to minimise heat losses. This keeps more heat in the water, reducing operating costs and making Rheem Heat Pumps more efficient



Applications

Heat pumps are proving to be a popular choice amongst new home builders, selected to meet building codes encouraging sustainable development. The Rheem Heat Pump meets the requirements specified within the New Zealand Building Code. Their popularity is derived from efficient operation, reduced Greenhouse Gas Emissions (GGEs) and simple installation providing a real choice for consumers in the sustainable energy market.

The replacement market also represents an excellent opportunity for the new Rheem Heat Pump. The unit can be quickly and readily installed, providing abundant, inexpensive and efficient hot water supply.

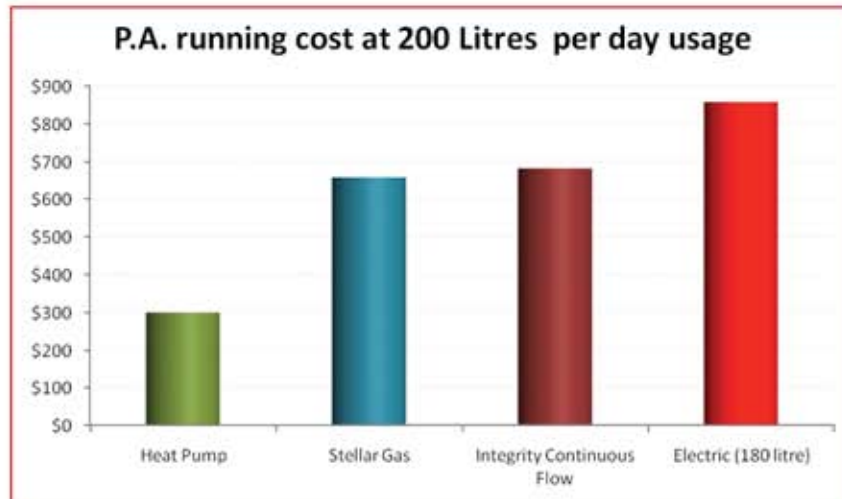

* Daily gas line charges included

* Auckland energy prices

* @ 45°C Rise



HDi-310

The HDi-310 Heat Pump Water Heater is the perfect system for large families needing loads of hot water at an affordable rate. High recovery and with "top down heating", the HDi-310 will give you useable hot water in a hurry even if the cylinder is completely drained. The cold water is pulled from the bottom of the cylinder and heated, in one pass through the heat pump module, to 60°C and is then deposited back into the top of the cylinder.

The HDi-310 has a powerful 1200watt compressor producing noise similar to that of a domestic air conditioner, common sense installation should mean that this small amount of noise is never an issue. Unique to Rheem is the standard inclusion of a back up element to ensure adequate hot water delivery in even the coldest conditions.



Top Down Heating

The heat pump uses an advanced design to provide single pass top down heating. The flow of the water through the heat exchanger is controlled to ensure the cold water drawn from the bottom of the tank is heated to 60°C in a single pass and deposited at the top of the storage cylinder, available for immediate use. There is no longer the waiting for the entire tank to reheat to a useable hot water temperature.

The top down heating and controlled heat exchange method of heating the water results in a hot water temperature of 60°C – 62°C in the water heater all year round. The temperature of the heated water is relatively uniform throughout the tank.

Installation and Handling

The Rheem heat pump offers the transportation advantages of a split system whilst providing the installation advantages of an integrated system.

The heat pump water heater is manufactured and cartoned in two components. The storage tank is separate to the heat pump module. The combination of lighter, more manageable cartoned components and integrated product design makes transportation, handling, and installation in both the warehouse and on site much easier. The storage tank is a similar weight and size to a 315 litre electric water heater.

The heat pump has a compact single footprint when installed, making efficient use of space. During installation, the heat pump module is positioned atop the storage tank, interconnecting to form a standard cylindrical shape. Assistance will be required to lift the heat pump module into position. All that is then required is to connect cold water and hot water plumbing connections, the electrical supply which must be hard wired. The cold water and hot water connections are comparable in position to a similar size electric or gas



heat pump module

+



storage tank

=



heat pump water heater



water heater. There are no remote components to connect to the Rheem heat pump, which means no roof work or connection between the tank and a remote heat pump module, thus reducing installation time and costs.

Note: When installing the HDi – 310 as part of a “ring main” system it is important given the systems “top down heating” capability that hot water is not returned to the bottom of the storage cylinder. Please see the detailed schematic on page 5 of the installation guide to ensure proper operation of the HDi – 310 when installed as the heat source for a re circulating main.

Powerful Compressor

The Rheem heat pump has an increased compressor size. It utilises a rotary air conditioning compressor of 1300 watts nominal motor input and a nominal motor output of 1200 watts. This equates to quicker recovery providing hot water faster. The recovery rate at 20°C ambient air temperature and 60% relative humidity is 71 litres per hour at a 45°C temperature rise. This is equivalent to a 3.7 kW element and provides a co-efficient of performance (COP) of 3.1 under these conditions. The entire tank can be heated from cold in as little as 3 hr 20 min.

Heat Pump Performance Specifications

Ambient air temperature (°C)	60% RH	60% RH	80% RH	80% RH
	Litres	COP	Litres	COP
10	58	2.5	55	2.44
20	71	3.08	73	3.19
30	88	3.8	92	3.91

Noise

The heat pump module produces a sound rating of up to 60 dBA (measured at 1.5 m) when it is operating. This is similar to a domestic air conditioner. Given noise appears relatively louder during quiet periods, particularly during the night/early morning, the unit can be fitted with a timer (supplied by others) to prevent it operating in these times if required. It is advisable to install the water heater away from bedroom or living room windows

Electric Boosting Backup

The heat pump has a freeze mode to reduce the heat pump operation in cold weather. At temperatures between 0°C and 5°C, the water heater switches to electric booster element heating, providing 220 litres of boosting under these conditions.

As heat pumps are more efficient the warmer the weather, this innovation reduces the heat pump control system operation in cold weather when it would normally work harder and longer. The reduced duty on the heat pump results in increased service life of the heat pump and quieter cold winter operation, particularly late at night or early in the morning. It also means there is no minimum operational temperature for the water heater, so hot water can be supplied whatever the outside air temperature.

The heat pump module and back-up heating element operate non-simultaneously. When the back-up booster element is operational, water continues to be drawn from the bottom of the tank, creating a circuit effect with the water level. The water is passed through the heat pump module. As the heat pump module is not operational, the water is deposited at the top of the tank cold, and begins being heated by the element. Consequently, water located beneath the element can be heated.

A secondary heat pump module failure mode also exists. In this circumstance, the element is activated to heat the water. The element heats the water to 70°C.

The back-up booster is a 3.6 kW (15 amp) element.



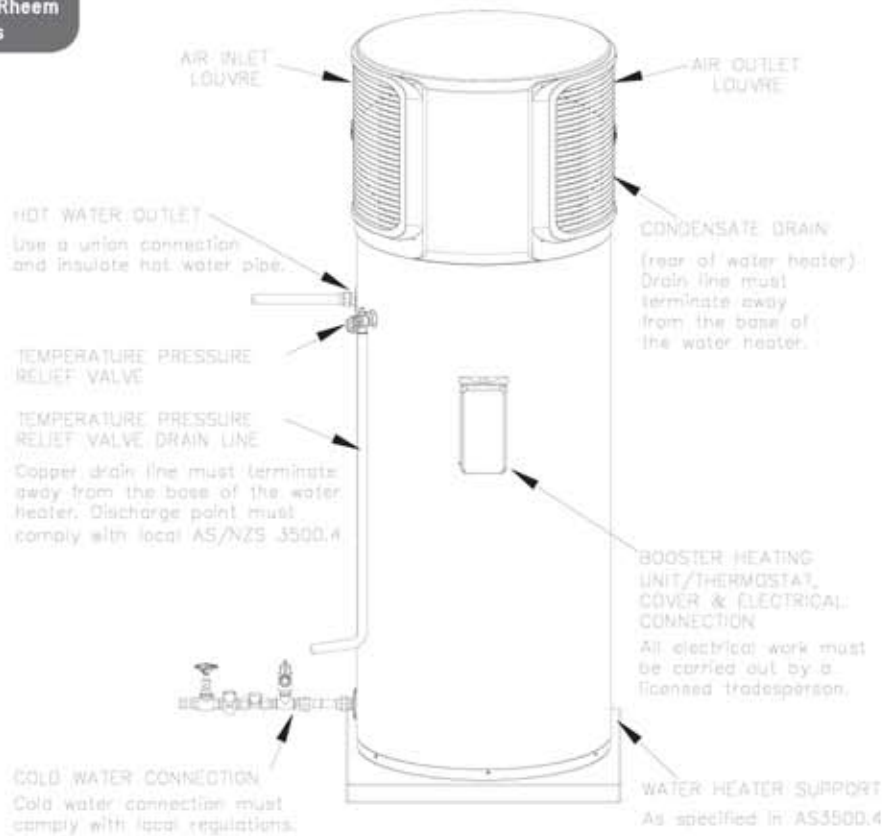

Installation (typical) Outdoor Locations only Heat Pump Air Sourced Electric Boosted Water Heater

Top Down Heating

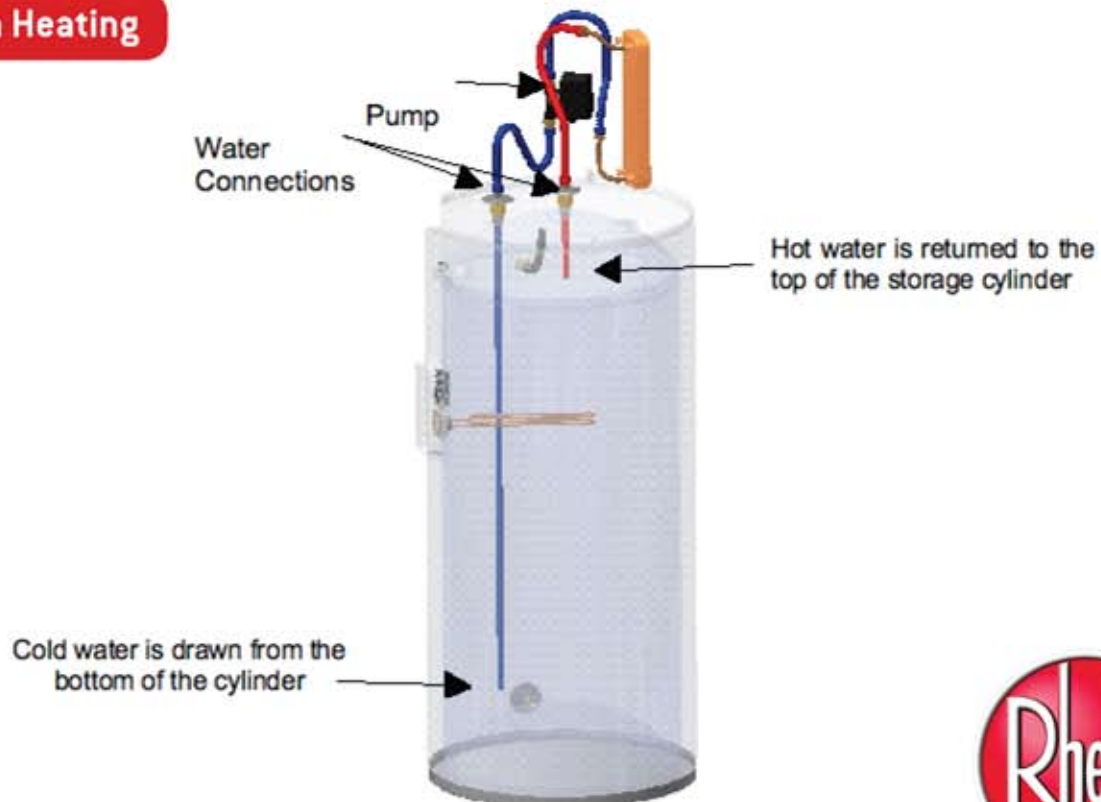

MPI-325



Designed with the smaller family or couple in mind, the MPI-325 can provide hot water at a third of the cost of a standard water heater. A smaller compressor allows a lower operating noise level making the MPI-325 one of the quietest on the market. The large 325 litre cylinder means the heat pump runs at a constant optimised rate topping up as water is drawn off. Although the cylinder is 325 litres this system would suit a household using up to 200 – 250 litres of hot water per day. A back up element is also standard with this model and the simple two piece design allows for easy installation by one person.

Noise

Featuring Whisper™ technology, the MPI-325 is among the quietest heat pumps on the Australasian market. Given that the noise output of other heat pumps is dominated by the sound of the compressor 'buzzing' away, nothing could be more dissimilar when it comes to the MPI-325.

It's only noticeable sound is that of a gentle fan swish as the air is drawn through the fan. It is completely inoffensive, and unlike other units with a higher pitch noise output, cannot be heard inside a dwelling. In fact, if you are a few metres away from the heat pump, you can't hear it at all.

Many other heat pump models locate the heat pump module in direct line of sight to windows, so noise is able to travel more easily into the dwelling, or that of a neighbour. With the MPI-325, when installed and operating, the heat pump module is located at ground level, and positioned parallel to an adjacent wall. This directs what little noise there is in a path that minimises its ability to cause a disturbance.

Given that any noise seems relatively louder during quiet periods, particularly during the night/early morning, the unit can be fitted with a timer to prevent it operating in these times if required.

FEATURES

Large Storage Capacity

The MPI-325 has a storage capacity of 325 litres which when full is more than equivalent to a 250L continuous recovery electric water heater in performance.

In addition to its large capacity, the MPI-325 stores 285L of water above 60°C, ensuring a plentiful supply of hot water is available.

Multi-Pass Heating

The MPI-325 heat pump works in much the same way as an electric water heater, or solar water heater. Unlike the HDi-310 heat pump model that features top down heating in a single pass to 60°C, the MPI-325 constantly heats water in approximately 10°C increment cycles. It does this by pumping water through the heat exchanger until the whole tank is hot. On a typical 20°C ambient day, this process takes approximately 9 hours to heat the whole tank, assuming the tank is completely drained of hot water.

Installation and Handling

The MPI-325 heat pump offers the transportation advantages of a split system whilst providing the installation advantages of an integrated system.

The heat pump water heater is manufactured and cartoned in two components. The storage tank is separate to the heat pump module. The combination of lighter, more manageable cartoned components



and integrated product design makes transportation, handling, and installation in both the warehouse and on site much easier. The storage tank is a similar weight and size to a 315 litre electric water heater.

The heat pump has a slightly larger footprint than the current HDi-310 heat pump when installed, as the module is located onto the front of the storage tank during installation. But because the heat pump is installed to face parallel down an adjacent wall, it is unlikely to cause an obstruction to narrow passageways. In essence, it is only occupying dead space. The upside to this is that the MPI-325 can now be installed easily by a single man, as a lift for the heat pump module onto the top of the storage tank is not required.

Connection is also easy. The heat pump module is located in close proximity to the tank. Two flexible hoses marked inlet and outlet are made by the plumber to the reciprocating fitting. Two plug-in electrical connections are also made, one carrying mains power, the other connecting to the sensor. The module is attached to the tank via 6 screw connections, starting with the 3 screws located closest to the wall. The unit is then plumbed as any other electric water heater would be.

*** Make electrical connections at the storage tank before attaching the module.**

A minimum pressure of 200kPa is required for the pump to operate.

The Rheem heat pump requires a clean air supply. It is important that the air inlet and air outlet are free of obstructions at all times. A clearance of at least 300mm is required around the air inlet (not adjacent to the wall) and from the fan outlet.

As the heat pump extracts heat from the surrounding air, the discharged air can be quite cool. This can cause condensate to form, which must be piped away from the heat pump and its controls. A condensate drain is provided in kit form, and is fitted at time of installation.

If a Rheem heat pump is being replaced, prior to its disposal, the refrigerant must be recovered from the sealed system. The refrigerant must not be vented to the atmosphere.

Dimensions & Specifications

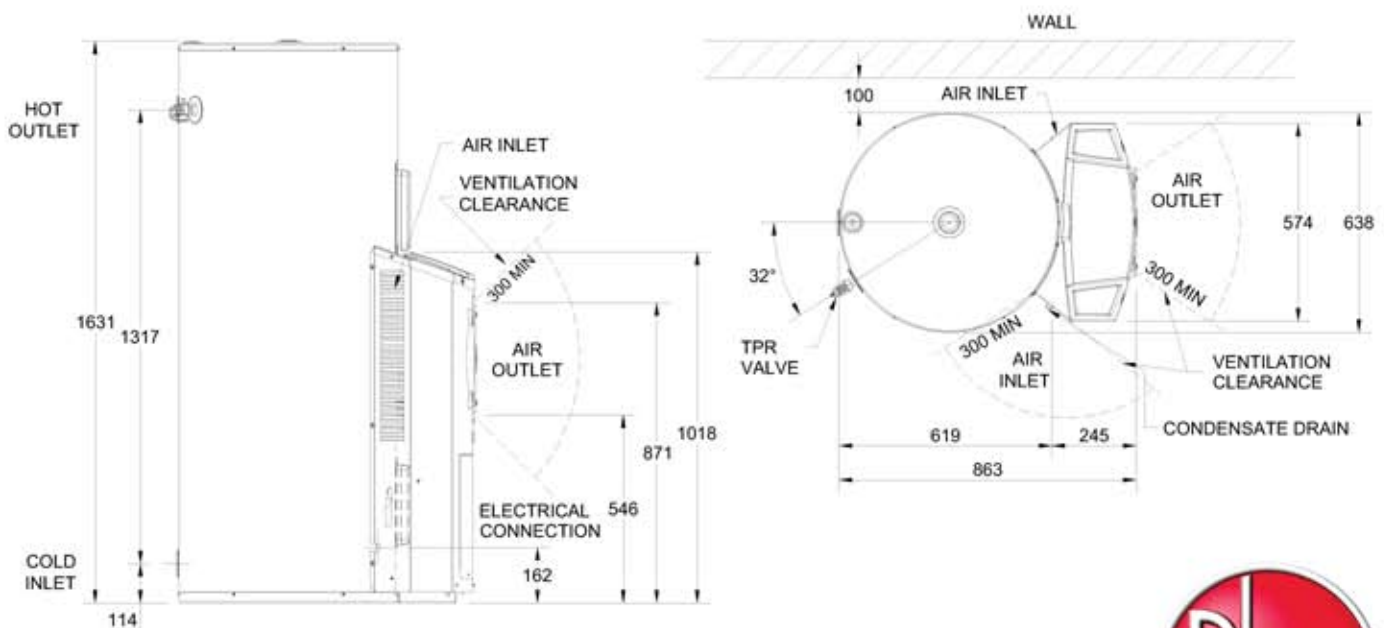

System Model Number	551 325 07
3.6kW	551 325 07
Minimum rated power input	3600 watts
Rated heat pump power input	800 watts
Booster element rating	3600 watts
Refrigerant type	R134a
Refrigerant circuit pressure	3000kPa

Part Numbers	
Tank only 3.6kW	T551 325 07
Heat Pump Module	180550
Storage Capacity	325 litres
Boost Capacity	100 litres
Mass empty - total	136 kg
Storage Tank	88 kg
Heat Pump Module	48 kg
Mass full - total	461 kg



heat pump module

+



storage tank

=

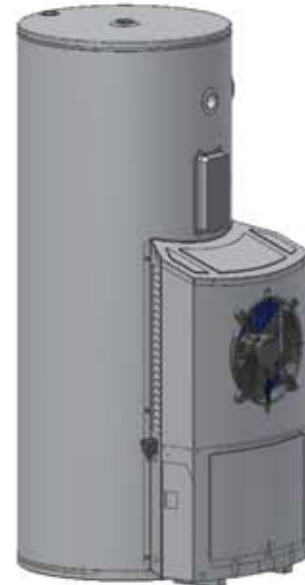

heat pump water heater

Compressor

The Rheem MPI-325 heat pump features a relatively small sized compressor. It utilises a rotary air conditioning compressor of 800 watts nominal motor input. It has been sized to deliver constant recovery over longer running cycles, minimising both energy consumption and noise production.

To assist further with noise abatement, the compressor is fully acoustically insulated.



Performance

Below is a table that published the MPI-325 heating rates and COPs at various average temperatures.

Ambient Air Temperature	COP	Heating Power	
		kW	L/hr
10°C	2.3	1.34	25
20°C	3	1.77	34
30°C	3.6	2.19	42

*Relative humidity during test conditions was 60%

Electric Boosting Backup

The MPI-325 heat pump has an anti-freeze feature for extremely low ambient conditions. Depending on water usage patterns, in instances where the ambient temperature is so cold that the evaporator can freeze, the water heater switches to electric booster element heating, providing 100 litres of boosting under these conditions. This water is heated to 70°C. In cold ambient conditions, heat pumps not only become less efficient, but lose their ability to produce usable hot water fast enough. At 10°C, a Rheem heat pump will typically still have a very respectable COP of 2.4, but may take up to 11 hours to heat a full tank of water. Whilst a 3.6kW element has a constant COP of approximately 1, still some 60% less efficient than a heat pump, it will take less than half the time to heat the same volume of water, to a higher average temperature. The MPI-325's back-up heating element therefore ensures hot water is available even in the coldest winter months.

A secondary benefit to this is in a break-down scenario. Even if for some reason the heat pump module fails, the unit will default to the element, and continue to provide hot water until a service call can be arranged.

The back-up booster is a 3.6kW (15 amp) element.

Operating Mode Monitor

An operating mode monitor is located on the front of the heat pump module and houses a green and a red LED.

The green LED, marked "normal", indicates the operational mode of the heat pump water heater and the red LED, marked "attention", indicates a fault mode.



Flashes	Operational Modes
Solid Green (remains on)	Standby mode - waiting to heat
1 x green	Call for heating received - system checks performed (heat pump heating or heating unit operation determined)
2 x green	Pump commences circulation at full speed
3 x green	Compressor and fan operation established (heat pump operating)
long green	Element heating unit on - ambient air temperature below 3°C to 5°C or above 45°C to 55°C
no green (remains off)	Call for Service



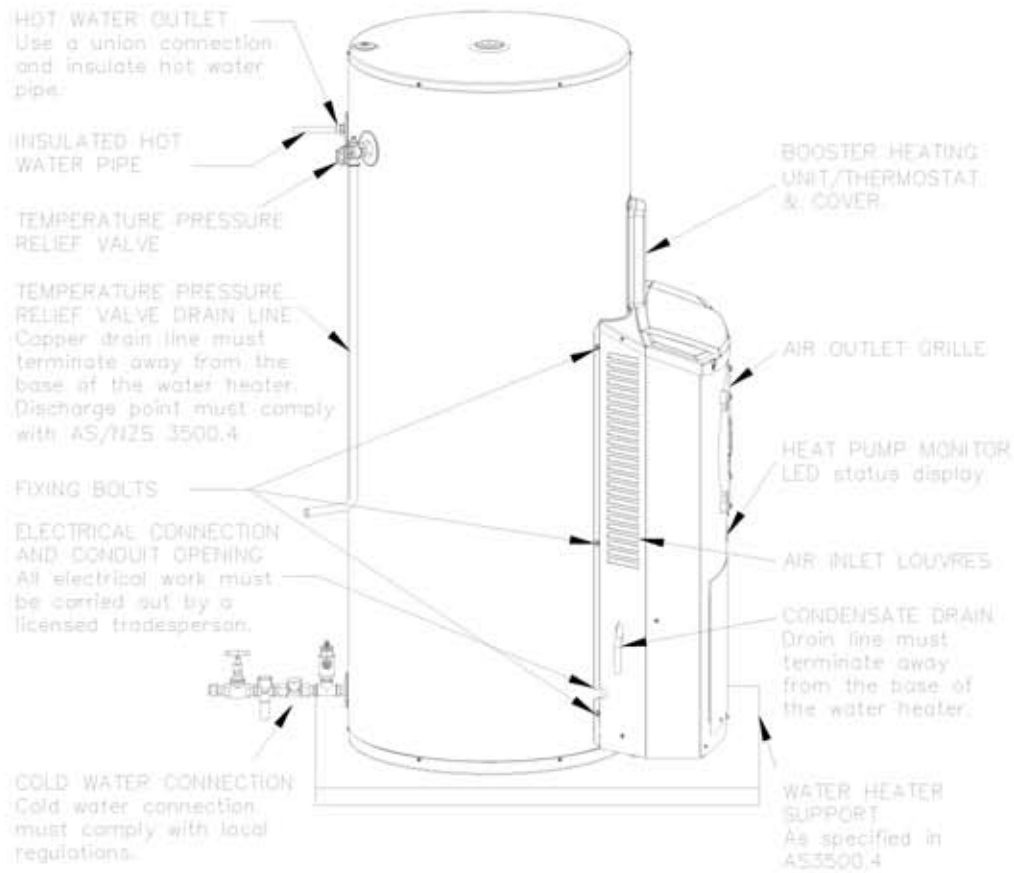

Installation (typical) Outdoor Locations only MPI-325 Heat Pump Water Heater



MPs – 325 Split Heat Pump

The MPi – 325 is also available as a split unit enabling the storage cylinder to sit inside through the wall from the actual heat pump unit (max distance of 4metres).

This is great for dwellings where space outside the building may be compromised due to paths or access ways. The actual heat pump operating specs are the same as the MPi – 325 integrated model except for details pertaining to the split installation.



FEATURES

H₂O Connect™

Unlike other split system heat pumps on the market, the new MPs-325 is plumber friendly, as water, not refrigerant, flows between the tank and module. This means you don't need a refrigeration mechanic to install the heat pump, as this can be done by a plumber.

Installation Flexibility

Thanks to its split design, the storage tank can now be located internally or externally. The Heat Pump module must remain outdoors either mounted to a slab or a wall, making it ideal for efficient space utilisation.

Multi-Pass Heating

The MPs-325 heat pump works in much the same way as an electric water heater, or solar water heater. The MPs-325 constantly heats water in approximately 10°C increment cycles. It does this by pumping water through the heat exchanger until the whole tank is hot. On a typical 20°C ambient day, this process takes approximately 9 hours to heat the whole tank, assuming the tank is completely drained of hot water.

Installation and Handling

The MPs-325 is available as two separate packages. One box contains the 325L tank, the other the Heat Pump module. As such, the MPs-325 is easy to deliver to, and handle on site.

As the MPs-325 is a 'remote' configured Heat Pump, the plumber will need to make the hot and cold water connections using either 1/2" copper or thermal resistant PEX piping between the heat pump module and the storage tank. Thanks to the H2O Connect feature, and unlike other brands of split heat pumps, the plumber can install the unit rather than a refrigeration mechanic. This distance is limited to 4m's, as determined by the length of the wiring harness. The wiring harness provides both a plug-in mains power connection and two sensor connections.

The plumber will also need to make typical cold water inlet (to the tank), and hot water outlet (to the house) connections.

Both the tank and heat pump module will typically require a 600mm x 600mm slab for mounting.

A minimum pressure of 200kPa is required for the pump to operate.

The Rheem heat pump requires a clean air supply. It is important that the air inlet and air outlet are free of obstructions at all times. A clearance of at least 300mm is required around the air inlet (not adjacent to the wall) and from the fan outlet. The remote configuration of this unit provides the installer with the flexibility to achieve these clearances, whilst choosing the optimum location for the Heat Pump to avoid noise disturbance.



Dimensions & Specifications

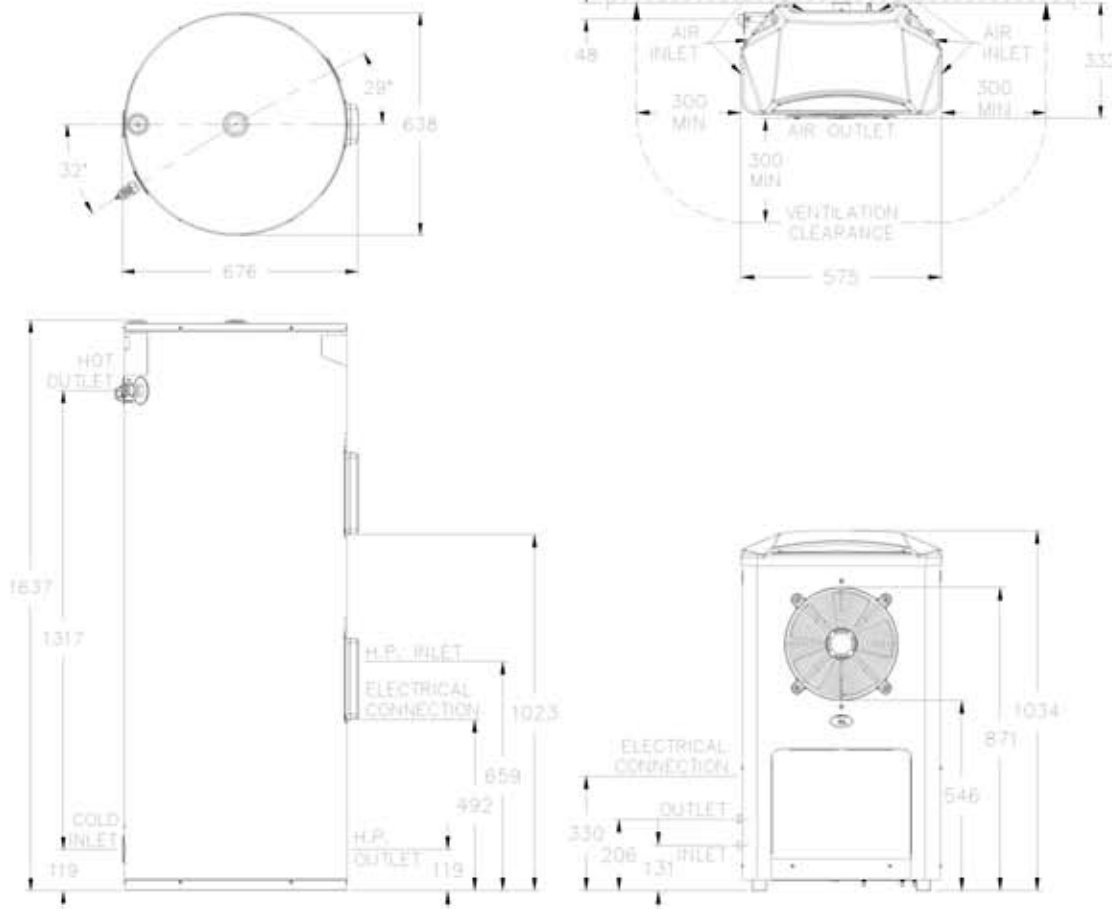

System Model Number	561 325 07
3.6kW	561 325 07
Minimum rated power input	3600 watts
Rated heat pump power input	800 watts
Booster element rating	3600 watts

Part Numbers	
Tank only 3.6kW	T561 325 07
Heat Pump Module	180536
Storage Capacity	325 litres
Boost Capacity	100 litres
Mass empty - total	136 kg
Mass full - total	461 kg

Notes:

- Power must be available at the water heater and to the heat pump for the LEDs to glow or flash.
- Time controlled power supply (power must be available at the water heater)
If the water heater is connected to a time controlled power supply, such as an Off-Peak (overnight) or Extended Off-Peak (overnight and day) supply, or controlled by a timer, then during periods of no power supply at the water heater the LEDs will be off. This is not a fault condition, but a result of no power being available to energise the LEDs. The green LED will recommence glowing or flashing when power is available again at the water heater.



Product Details

Model number 56132507 consists of:

- Tank (T56132505)
- Heat Pump module (180536)
- 3.6kW booster element

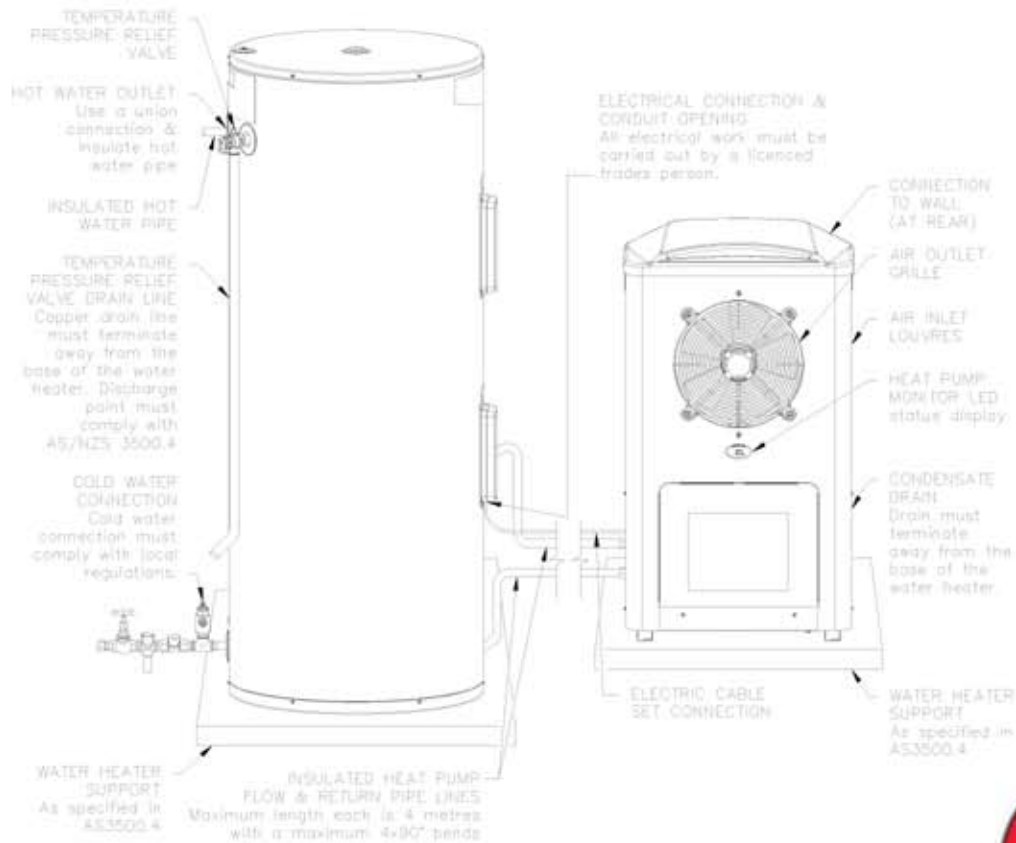
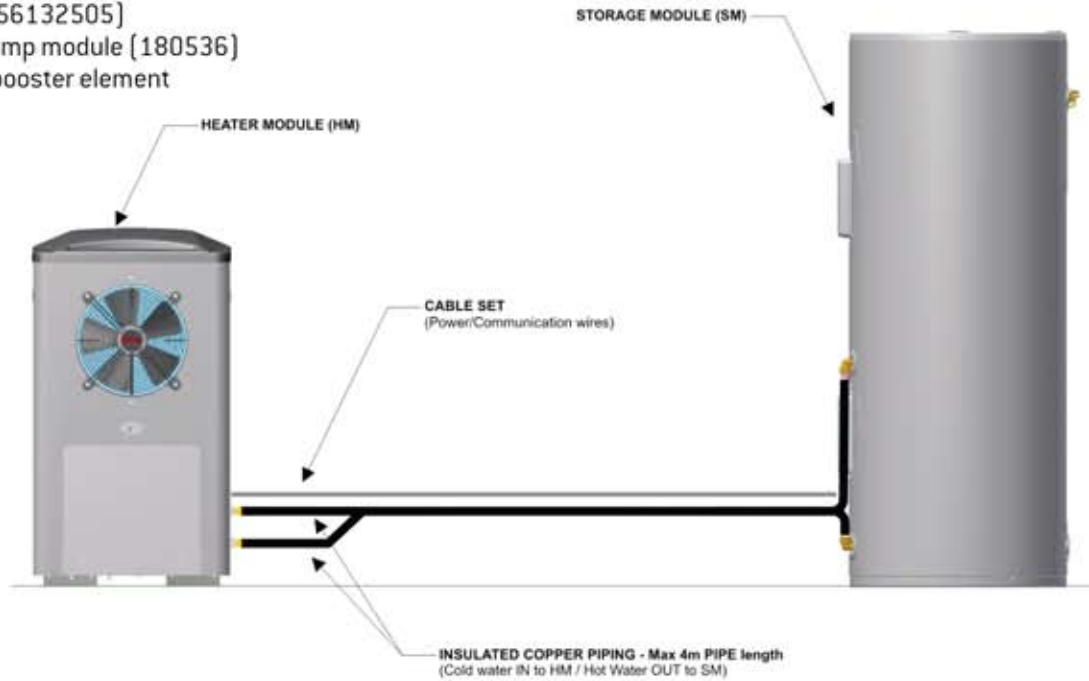

Installation (typical) Outdoor Locations only
MPs-325 Heat Pump Water Heater



Sizing

	ZONE	PEOPLE
HDI-310	1	3 - 6
	2	3 - 5
MPi-325 / MPs-325	1	1 - 4
	2	1 - 3



Electric Boost Specifications				
Heating unit type *		Copper sheath immersion element		
Supply Voltage		240V		
Rating	Current	40°C	50°C	60°C
kW	Amps	litres	litres	litres
3.6	15	77	62	52
* Low watts density elements are available for hard water areas and incolloy elements are available for corrosive water areas.				

† Warranty Details

Single family domestic dwelling only: 7/2, 7 year cylinder, 2 year labour on cylinder, 2 year sealed system including labour, 2 year parts including labour.

Other installations: 3/1, 3 year cylinder, 1 year sealed system, 1 year parts, 1 year labour.

Note: warranty does not apply to the heat exchanger in hard water areas unless a water softening device is installed or in areas with a Chloride content > 250 mg/L.

Materials and specifications are subject to change without notice.

This system is suitable for multiple installations and outdoor installation only. This system is suitable for frost regions but is not suitable for hard water areas.

Rheem New Zealand Limited

Freephone 0800 657 336 • Freefax 0800 657 337

Telephone 09 829 0200

PO Box 19011, Avondale, Auckland 1746, New Zealand

www.rheem.co.nz

