

Rheem Premier Solar



RHEEM PREMIER SOLAR	
MODEL - ELECTRIC BOOST	A591270 2/T A591270 3/T
MODEL - GAS BOOST	A591270 2/TG A591270 3/TG
DIMENSIONS	1865 x 670
INSTALLATION	Internal or External
FROST PROTECTION	Drain Back
WARRANTY	7 years

General Solar Overview

There are 4 main types of Solar Water Heating:

- Open loop or direct, where the water that is heated in the collectors is the water that is stored in the cylinder and used in the home.
- Closed loop or indirect, where the heating fluid in the collectors is passed through a heat exchanger in the cylinder. The heat in the fluid is transferred into the potable water.
- Roof Mounted, where collectors and cylinders are both mounted on the roof. This method utilises thermosiphon to move water through collectors and cylinder.
- Split system, where the collectors are mounted on the roof and the cylinder at ground level. A pump is then used to circulate liquid through the heating loop.

Rheem Solar Introduction

Rheem Premier Solar is a closed loop or indirect, split solar water heater system specifically designed for environments prone to frost and/or with poor water quality. The collectors are mounted on the roof while the solar storage tank is located at ground level.

The revolutionary system combines an "in tank" heat exchanger in a proven vitreous enamel lined cylinder with Rheem's high efficiency, multi riser, 'T200' collector to produce a system with superior solar performance.

The system is factory charged with the correct amount of heat exchange fluid which requires no further filling on site. During periods of solar gain, the heat exchange fluid is pumped through the collectors to capture the sun's energy. When heating is complete or during periods of frost the fluid drains back to the tank providing total frost protection to -17°C.

The heat exchange design is also perfectly suited for areas of poor water quality because heat transfer fluid (glycol) passes through the collectors instead of water, which can form calcium in the collectors. The heat exchange circuit is kept clean and maintains peak performance for the life



of the system. With the correct selection of anode, vitreous enamel tanks have proven to be the most durable for all water conditions found in New Zealand.

Rheem Premier Solar is available in a 270 litre model with 26 litre a minute remote in-line gas boosting (gas type can be either Natural or LPG) or Electric boosting via a 3.6 kW element positioned to supply 135 litres of hot water when required.

Summary of Installation Features

Ease of installation is a key feature of Rheem Premier Solar.

- The tank is suitable for mounting in any upright position whether internal or external – in gas boosted models the continuous flow unit must be mounted externally.
- Solar flow and return lines are located on top of the storage tank to facilitate easy installation and a neater finish.
- Solar pump and controller are mounted within the unit to save space, reduce installation time and improve overall appearance.
- The system is pre-charged with glycol for peace of mind and quicker installation.

Boosting Options

Gas boost models utilise a specially developed 26L/min instantaneous gas water heater which eliminates the need for additional valving (by-pass valve) and provides an abundant amount of back up on those cloudy days. The boosting is conducted in-line. Solar heated water greater than the set point (58°C) will pass through the booster without igniting the burners, however should the solar pre-heat be less than the set point (58°C) the booster will ignite to deliver 60°C water.

Electric boost model has a mid mounted 3.6kW element that will supply 135litres of hot water when required.

Note: Remote controllers cannot be used with any instantaneous water heater used in conjunction with solar, as the solar heated water cannot be set by the remote controller.

Rheem Premier Solar provides the ultimate in flexibility with the gas booster unit mounted remotely enabling the cylinder to be positioned wherever it is required.

The electric boost provides 135 litres of continuous boosted hot water, and is designed for connection to a continuous electricity supply to guarantee sufficient hot water during periods of low solar gain. The element rating is 3.6kW.

It is possible to connect the element to a night rate tariff, an automatic timer or booster switch to control the boost function to best suit the user. The 3.6kW element, with a current rating of 15 Amps, is suitable for use with most timers and switches, including Rheem Time Clock P/No 12104800.

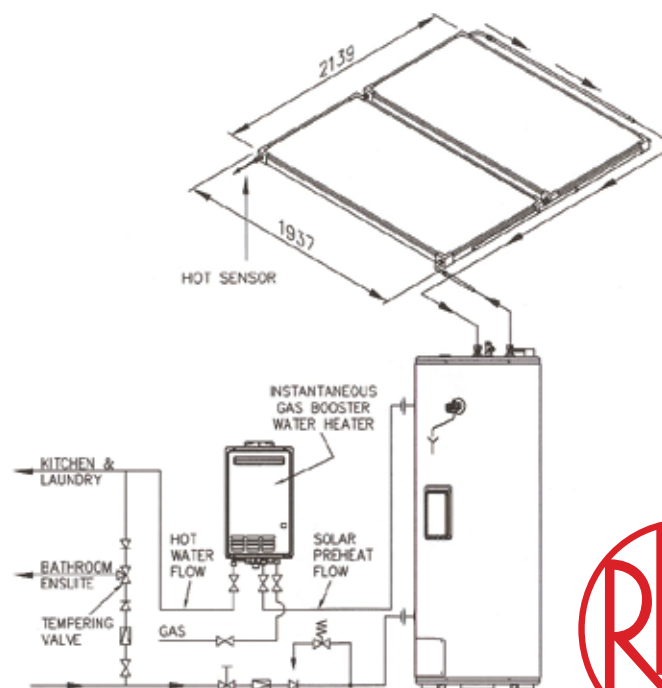

Operation

Rheem Premier Solar is unlike any other product on the market. Competitor closed circuit split systems utilise an externally mounted plate heat exchanger to transfer the heat from the collectors to the water in the tank. This is unsightly, requires more space and is prone to damage in the water side of the heat exchanger due to scale build up or corrosion in poor water quality areas.

Heat Exchanger

Rheem Premier Solar uses a well proven method of heat transfer by inserting a “tube heat exchanger” through the centre of the cylinder. The “tube heat exchanger” is capped at the top and bottom and is factory charged with the correct amount of heat exchange fluid to operate up to 3 collectors. Additional water may need to be added during commissioning if 3 collectors and/or maximum pipe runs are installed. The solar circulating pump and controller are located inside the base of the unit. This improves the installed appearance and reduces installation time.

The solar cold and hot lines are connected at the top of the water heater. The solar cold pipe, from the pump, is run from the bottom of the heater, under the jacket, and is accessed by the plumber via nut and olive connections at the top of the water heater. The solar hot pipe returns into the top of the heater and connects directly into the central heat exchanger via nut and olive connections.

Information from sensors located at the collectors, in the tank and in the heating circuit line communicate with the controller to turn on the pump when solar heating is available. The heat exchange fluid is pumped up to the collectors where the heat is gathered and falls back under gravity to the heat exchanger. The design of the heat exchanger causes the fluid to adhere to the inside wall of the “tube heat exchanger” which is in contact with the water in the tank.

This is known as “falling film technology” and is how the heat is transferred to the water in the tank.

When heating is no longer required or available, the pump is de-activated and the fluid drains back from the collectors to the heat exchanger reservoir.

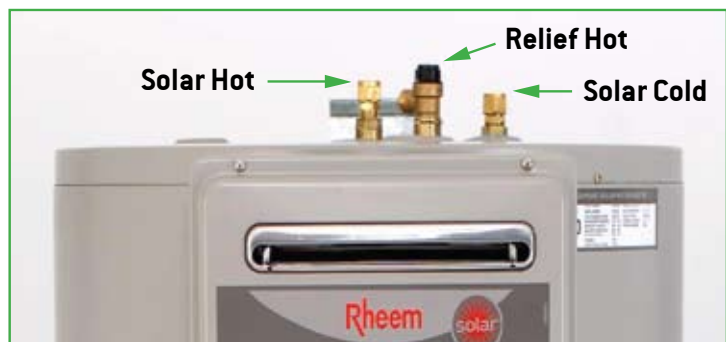

Pump

The pump in Premier Solar operates very differently to the circulator in an open loop Solar.

An open circuit solar system relies on the mains pressure to fill the entire circuit with water. Once the system is bled of air, the circulator simply moves the water around the circuit. Pressure lost in the circuit as the water flows up the pipe to the collectors is regained as the water moves down the pipe from the collectors.

By contrast, the pump in Premier Solar pushes the heat exchange fluid from the bottom of the tank to the highest point of the collectors every time solar heating is required. The operational limit on the pump is 9m vertical and 40m total flow and return length, with 20 x 90mm bends (see pipe out sheet). This should meet the requirements of most homes, however, if a height greater than 9m is required, a second pump will need to be fitted at the solar cold connection. A separate pump is available as a spare part, and instructions are included in the installation booklet.



Corrosion Protection

The heat exchanger is charged with nitrogen, an inert gas, which prevents corrosion of the system by displacing most of the oxygen. Any remaining oxygen in the system is quickly consumed upon start up, thereby eliminating oxidation.

Solar Relief Valve

The solar circuit has a pressure relief valve set at 200kPa. On a good solar day the pressure in the solar circuit will build and this pressure may be relieved by the valve in the form of vapour. Upon cooling, the pressure will be reduced and a slight vacuum may be formed in the circuit. This has no effect on the operation of the system.

Orientation

- Collectors may be installed on an angle that varies from the latitude angle by +/- 20%. Roof pitches below 10 may require a raised pitch frame.
- Solar collectors must be unshaded between 9.00 am – 5.00 pm. The chosen area must be structurally suitable for the water heater collectors. They weigh 48 kg each.
- Collectors should be installed facing north. Variation up to 45 East or West will have little effect on the total annual solar contribution. Variation above 60 East or West an additional collector may be required.

Minimum Inclination Angle

Auckland	20°
Hamilton	22°
Wellington	25°
Christchurch	30°
Dunedin	35°
Invercargill	37°

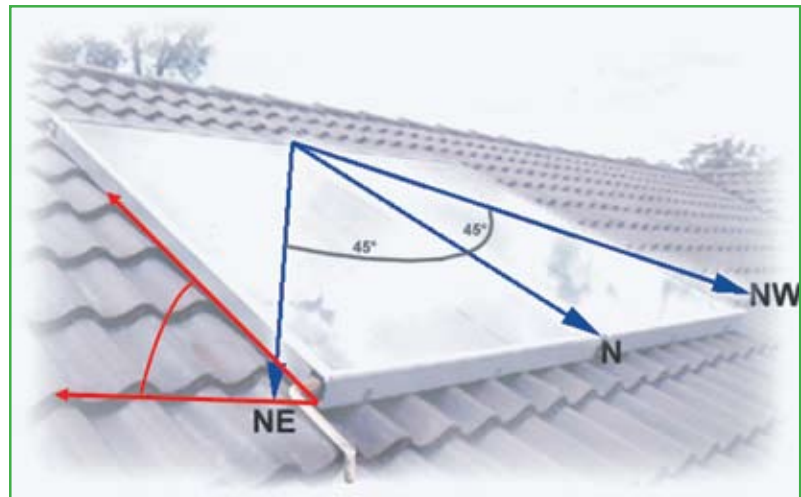

Installation Details

The Rheem Premier Solar closed loop system does not require any special plumbing to the heating loop. The Premier Solar systems drains back when solar heating is completed, therefore the possibility of stagnation and “flashback” is eliminated. This greatly simplifies the installation of the product.



- Copper pipe **MUST** be used between tank and collectors – plastic pipe **MUST NOT** be used.
- Copper or brass olives for compression fittings
- Insulate flow and return pipes with 13 mm, weather proof, UV resistant insulation
- Each pipe must fall continuously by at least 5°, or 1 in 10, to ensure proper drainback of heat exchange fluid into tank

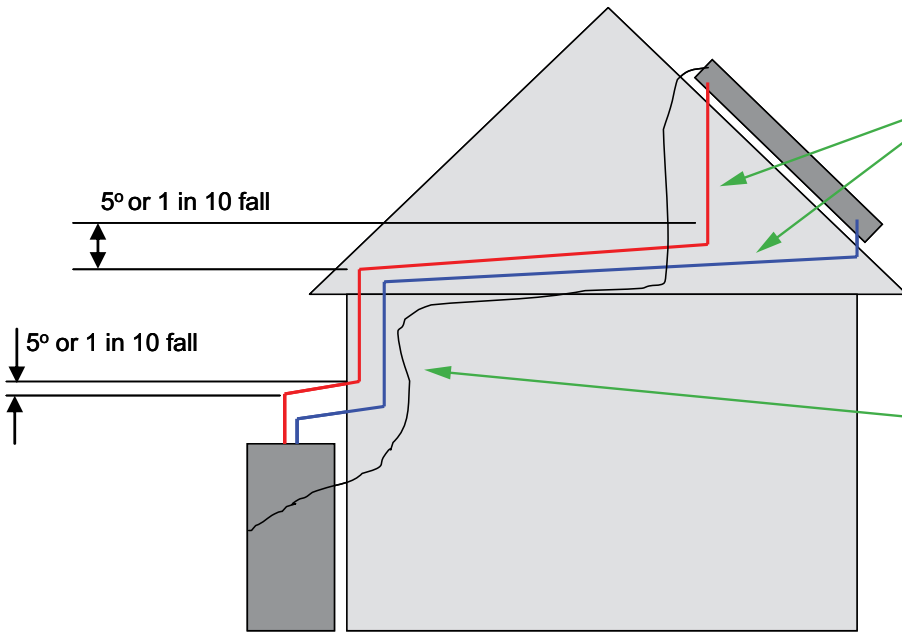

All pipe work **MUST** be hard drawn copper, DN15 and fully insulated.

Plastic piping must **NOT** be used as it will melt due to the high temperatures of solar heating.

Run hot sensor lead with plumbing at time of collector installation

Collector Rotation

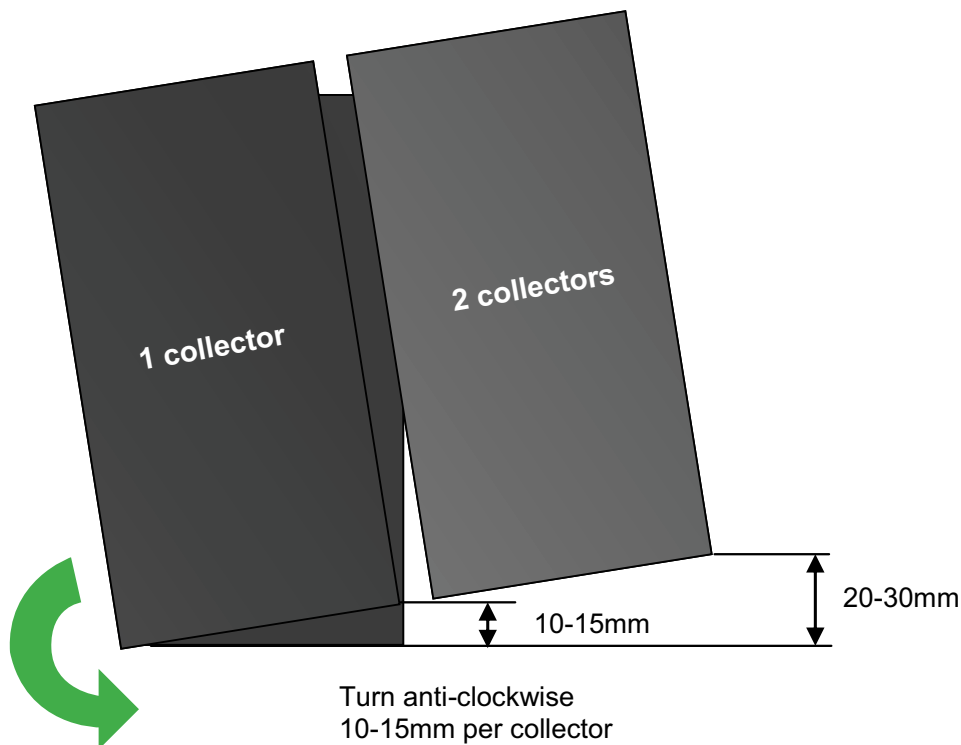

Roof Kits

Roof kits come as part of the Premier Solar system ordered – 2 or 3 as per requirements. Where a 3T system is specified a two collector kit and a 1 collector kit will be supplied that are coupled together to make up the 3.

Variable pitch collector stands can be ordered as extras as either for 2 collectors (Part No. A12106883) or 1 collector (Part No. A12106884) and as above, the 2 stands can be utilised to work as a 3 collector system.

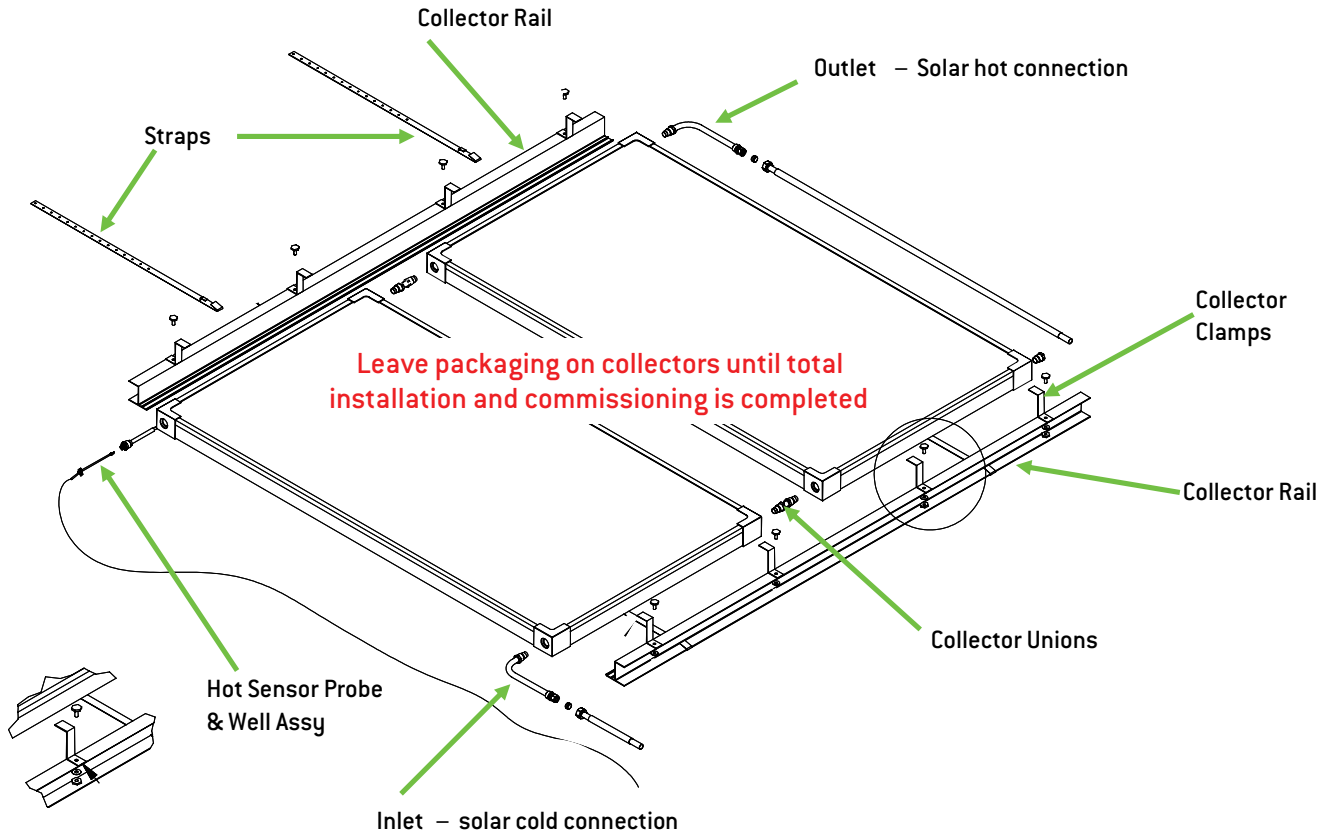

Technical Specifications – Electric and Gas Boost Models

Model		A591270/2T	A591270/3T	A591270/2TG	A591270/3TG	
Storage Capacity	Litres	270		270		
Suitable for	People	1-3		2-5		
Suitable for	Bathrooms	2		3		
Booster Alternatives		Electric		gas remote		
Boost Capacity	L/min @25°C rise			26		
Boost Capacity	Litres	135		-		
Gas Input Max	MJ/h	-		199		
Gas Type Available		-		Natural or LPG		
Minimum Flow Rate	L/min	2.7		2.7		
Booster Frost Protection		Standard		Standard		
Element Rating	kW	3.6		-		
Collectors		2 x T200	3 x T200	2 x T200	3 x T200	
Roof Space Required	W x H (m)	2.4 x 2.0	3.6 x 2.0	2.4 x 2.0	3.6 x 2.0	
Dimensions - Tank	H mm	1755		1755		
	W mm	650		650		
	D mm	680		680		
Weight Empty - Tank	kg	146		146		
	- Collectors	kg	48 96	48 96		
Temperature Pressure Relief Valve Setting	kPa	1000		1000		
Maximum Water Supply Pressure						
	- without ECV fitted	kPa	800		800	
	- With ECV fitted	kPa	680		680	
Minimum Water Supply Pressure	kPa	-		150		
Connections						
	Inlet	BSPF	3/4 / 20		3/4 / 20	
	Outlet	BSPF	3/4 / 20		3/4 / 20	
Gas	BSPM	-		3/4 / 20		
Solar Flow and Return		DN15 Compression		DN15 Compression		

Warranty

- 7 years on cylinder supply
- 7 years on collectors
- 10 years pro rata on Gas booster heat exchanger
- 1 year on parts including labour



Inside Rheem Premier Solar

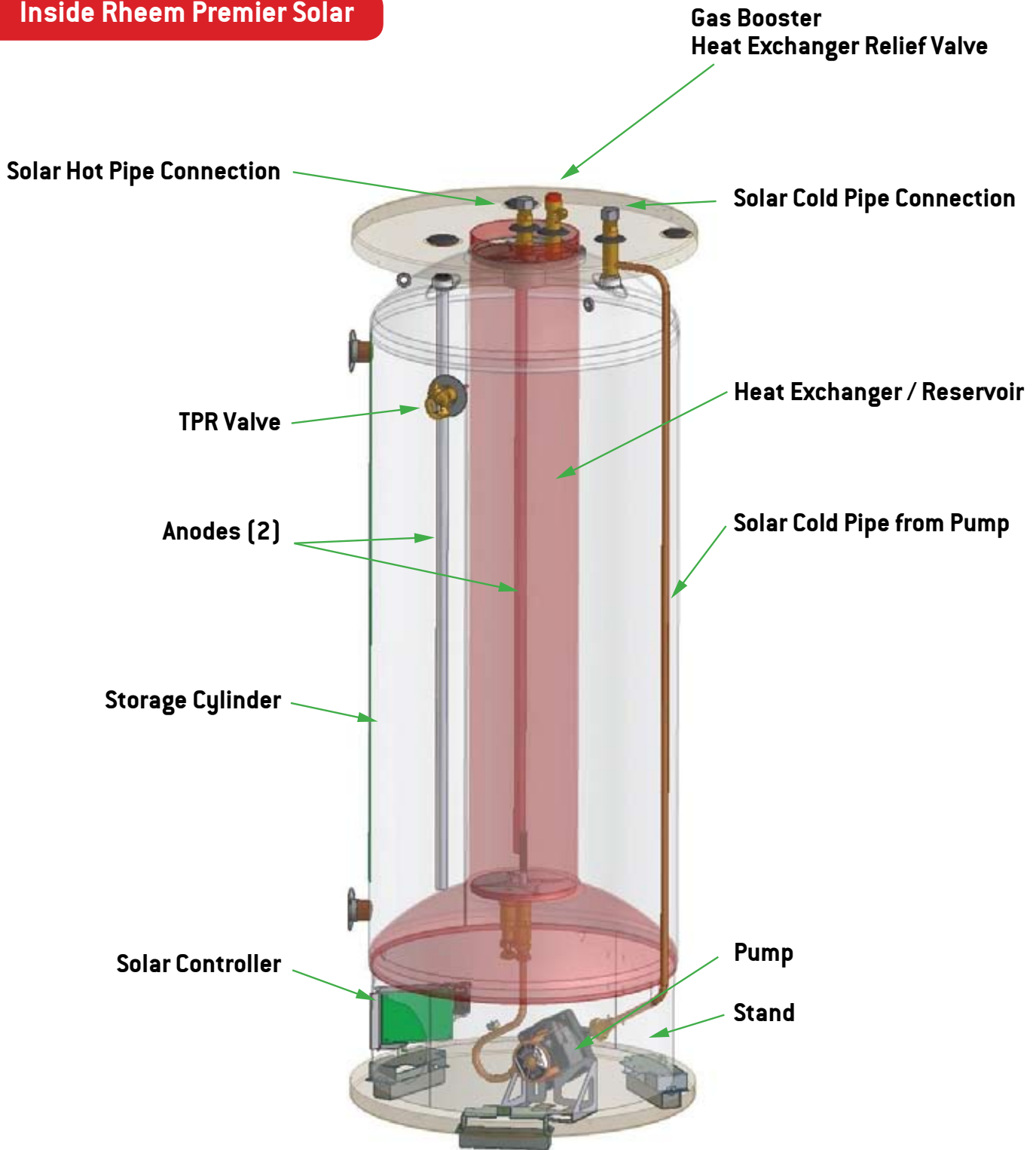

Rheem New Zealand Limited

Freephone 0800 657 336 • Freefax 0800 657 337

Telephone 09 829 0200

PO Box 19011, Avondale, Auckland 1746, New Zealand

www.rheem.co.nz



Solar • Feb 09